

Supply Module KDV 2.3

Applications

DOK-POWER*-KDV*2.3****-ANW1-EN-P

Titel KDV 2.3 Supply module for AC drives

Type of documentation: Applications

Documenttype DOK-POWER*-KDV*2.3****-ANW1-EN-E1,44

Internal file reference

- Mappe 6
- KDV23-AN.pdf
- 209-0049-4306-02

Reference This electronic document is based on the hardcopy document with document desig.: DOK-POWER*-KDV*2.3****-ANW1-EN-P • 02.97

This documentation is used: In this document you will find:

- the range of applications,
- the electrical lay-out,
- the mechanical lay-out of the control cabinet,
- mounting and installation guidelines,
- guidelines for selecting additional components, and,
- troubleshooting guidelines.

Change procedures

Designation of documentation up to present edition	Release-date	Coments
DOK-POWER*-KDV*2.3****-ANW1-EN-P	Feb./97	New Edition
DOK-POWER*-KDV*2.3****-ANW1-EN-E1,44	Jun./97	2nd E-Dok

Copyright © INDRAMAT GmbH, 1994
 Copying of this document, and giving it to others and the use or communication of the contents thereof, are forbidden without express authority. Offenders are liable to the payment of damages.
 All rights are reserved in the event of the grant of a patent or the registration of a utility model or design. (DIN 34-1)

The electronic documentation (E-doc) may be copied as often as needed if such are to be used by the consumer for the purpose intended.

Validity All rights reserved with respect to the content of this documentation and the availability of the products.

Publisher INDRAMAT GmbH • Bgm.-Dr.-Nebel-Straße 2 • D-97816 Lohr
 Telefon 0 93 52 / 40-0 • Tx 689421 • Fax 0 93 52 / 40-48 85

Dept ENA (DE, FS)

Table of contents

	Page
1. INDRAMAT's modular AC drive system	5
1.1. The design of the KDV 2.3 supply module	6
2. Applications	7
2.1. Functional power features of the KDV 2.3	8
2.2. KDV 2.3 power ratings	9
2.3. KDV 2.3 - technical data	10
3. Guidelines for installation and electrical connections	11
3.1. Terminal diagram	12
3.2. Mains connection - power section	13
3.3. Fuse protection for the power connection	14
3.4. Selecting the mains contactor	14
3.5. Power supply requirements	15
3.6. DC bus	16
3.7. Additional capacitance on the DC bus	17
3.8. Smoothing choke	17
3.9. Electronics and internal blower power supply	17
3.10. Wire-ribbon connection for the electronics and signal exchange ..	18
3.11. Fault current protective device	19
3.12. Checking the control cabinet	19
3.13. KDV 2.3 from the front	20
3.14. Installing the KDV 2.3 in the control cabinet	21
4. Control circuits (control of input power)	24
4.1. Differentiating features of the power circuits	25
4.2. Using the DC bus dynamic brake	26
4.3. DC bus short-circuiting switch	28
4.4. KDV 2.3 control circuits with dynamic braking	30
4.5. KDV 2.3 control circuits without dynamic braking	32
4.6. Control circuits for a controlled braking of the drives for an E-stop or power failure	34

5.	Interface descriptions	36
5.1.	Signal voltages	36
5.2.	Ready	36
5.4.	Feedback power too high	37
5.3.	Electronics supply working	37
5.5.	Power supply working	38
5.6.	Bringing the drives to a standstill with a fault in the power supply system	38
6.	Troubleshooting guidelines	40
6.1.	Troubleshooting	40
6.2.	Diagnostics displays	42
6.3.	Fault list and remedial actions	42
6.4.	Fuses	43
7.	Dimensional data	44
7.1.	KDV 2.3 supply module - dimensional data	44
7.2.	Dimensions: DST 3-phase AC autotransformer	45
7.3.	Dimensions: DLT 3-phase AC isolation transformer	46
7.4.	Dimensional data: CZ 1.02 additional capacitor	47
7.5.	Dimensional data: TCM 1.1 add. capacitor module	47
7.6.	Dimensional data: GLD 12/13 smoothing choke	48
7.7.	Dynamic brake contactor	49
7.8.	Dynamic brake resistor	49
8.	Order details	50
8.1.	KDV type codes	50
8.2.	Available versions	50
8.3.	Summary of the electrical connecting accessories	51
8.4.	Order details for mains supply with KDV 2.3	51
9.	List of INDRAMAT service reps	52
10.	Index	54

1. INDRAMAT's modular AC drive system

The modular INDRAMAT AC drive is made up of the following parts:

- control gears,
- a supply module, and,
- the drive modules,

which can be combined with each other components depending upon power or functions wanted.

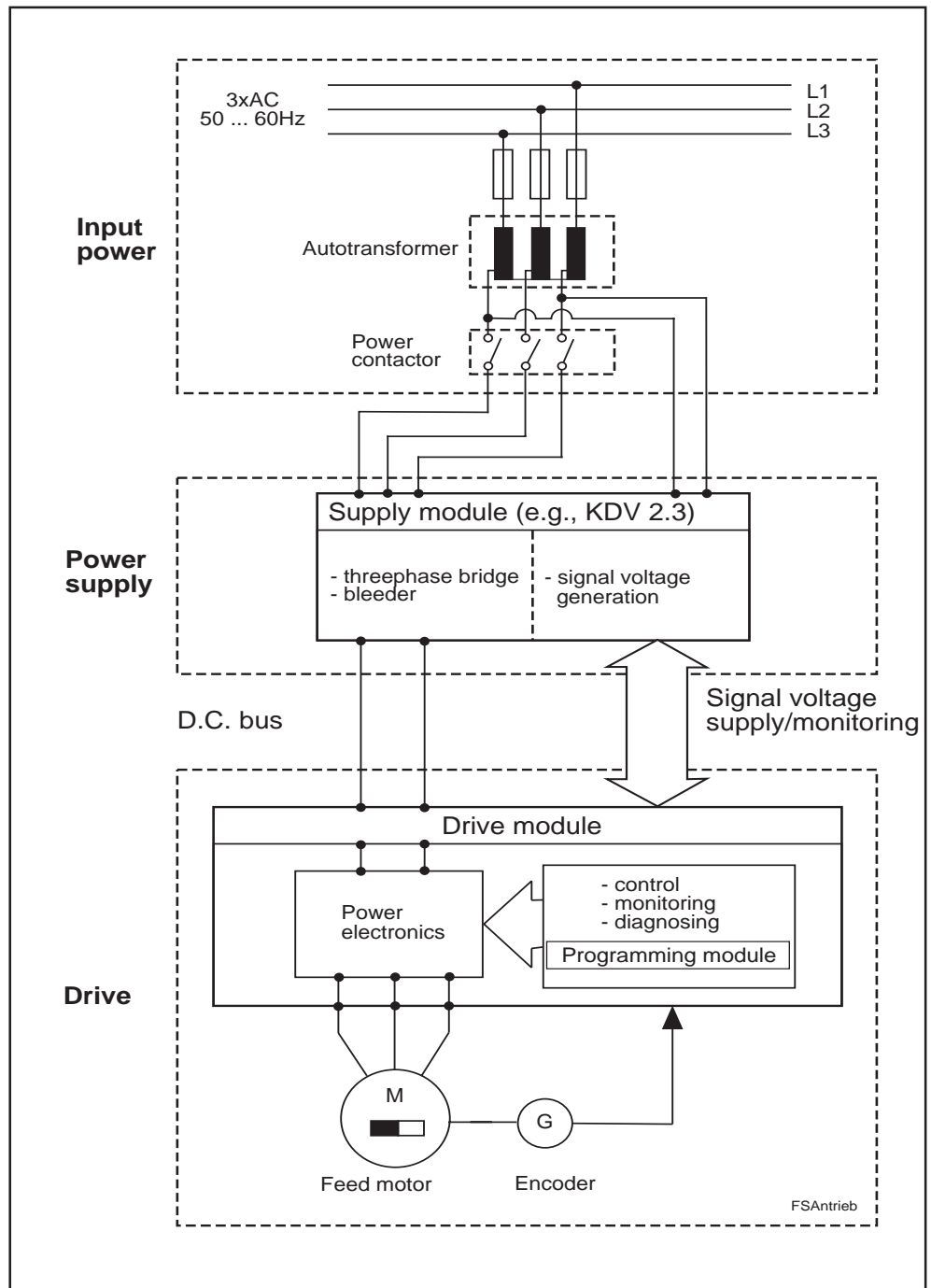

Figure 1.1: The KDV 2.3 supply module as a part of INDRAMAT's AC drive system

1.1. The design of the KDV 2.3 supply module

Power supply to the drives

The threephase bridge rectifies the threephase mains AC voltage and provides the DC high voltage for the drives.

When the drives are in generator-mode, the regenerated energy is absorbed by the bleeder and transformed into heat.

The buffer capacitance provides sufficient smoothing.

Power supply to the electronics

The KDV 2.3 provides the +24V and ±15V for all attached drive modules.

In the event of a power failure, the signal voltages receive their power from the DC bus. This means that the drive electronics can still function, when the drives are in generator mode.

Monitoring the drive system

The KDV 2.3 is equipped with extensive monitoring functions. These communicate with the drive modules via the signal voltage bus.

The Bb1 contact is of greater significance to drive system readiness. Power can only be switched on when this contact is closed.

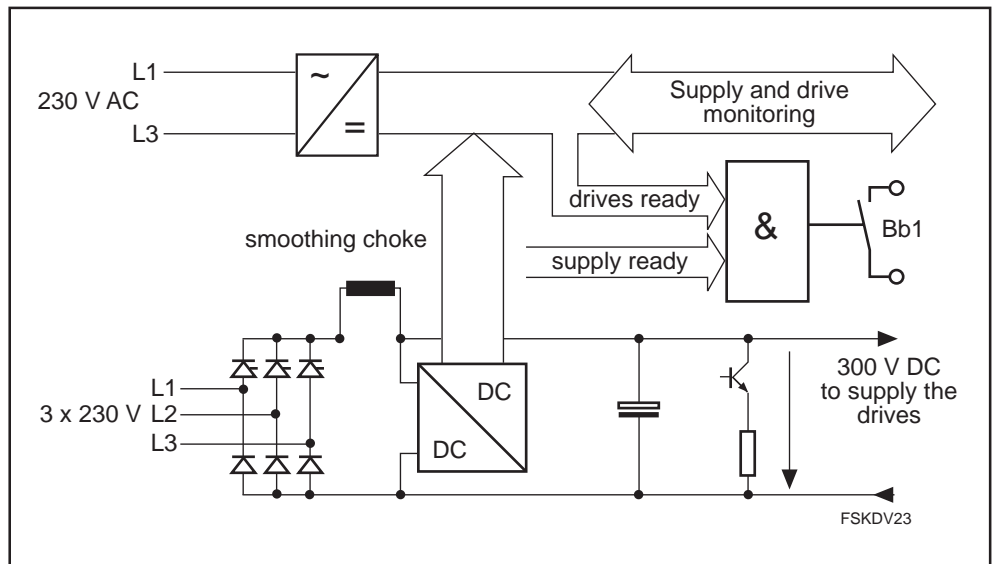

Figure 1.2: The design of the KDV 2.3 supply module

2. Applications

INDRAMAT's KDV supply modules can be operated with a continuous mechanical output of 24 kW. The continuous regenerative power can equal up to 2 kW.

Supply modules with mains regeneration are available for higher continuous regenerative power demands.

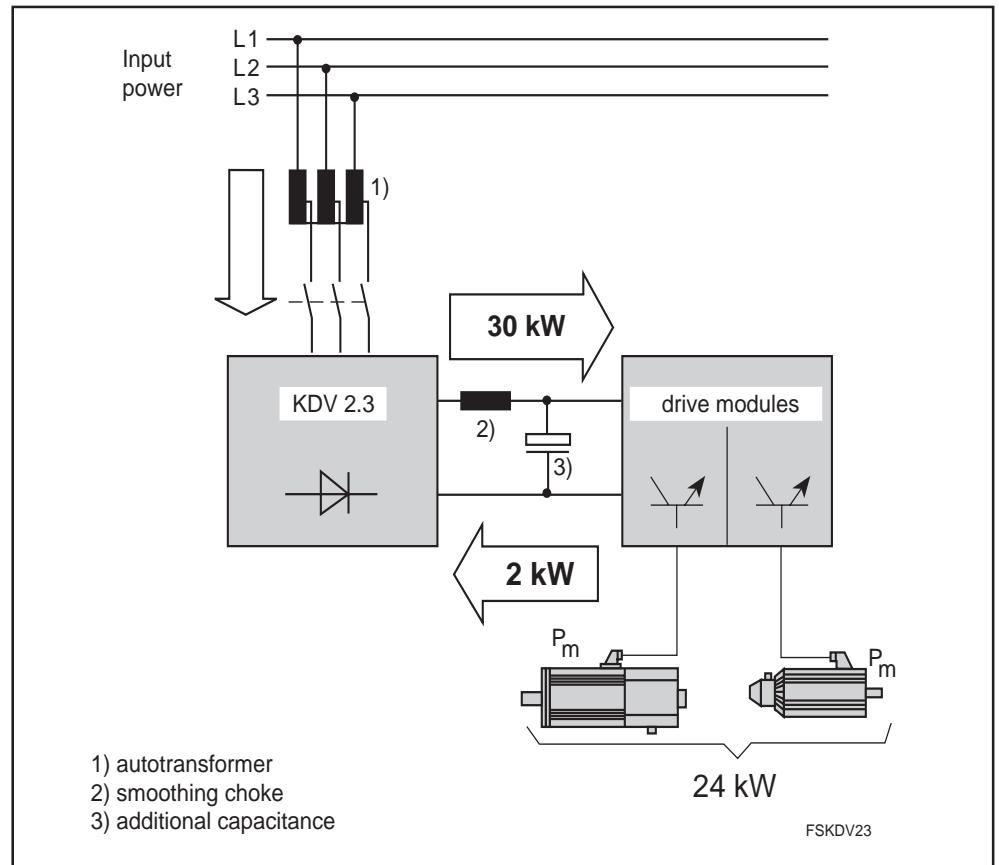

Figure 2.1: Power range of a KDV 2.3 supply module

2.1. Functional power features of the KDV 2.3

- **Simplified fusing**
Only overload protection for the power supply line is needed. Commercial power protection switches or slow-blow fuses can be used.
- **Ground fault monitoring of the attached drives**
In the event of a fault, power is immediately switched off by opening the Bb1 contact and signalled via the optical display on the LED.
- **Drive system response to a power failure**
Can be programmed by inserting the external NC bridge circuit:
 - Without the NC bridge circuit, the drives will brake with maximum torque.
 - With the NC bridge circuit, there is a signal to the NC control unit via a potential-free contact. It makes it possible for the NC control unit to brake the drive to a standstill, protecting expensive tools and workpieces against damage.
- **Limiting the charging current of the DC bus capacitors**
The charging current need not be taken into consideration when selecting the switching device for the power supply. The lifespan of the switching devices is increased.
- **High control voltage loads**
Six drive modules can generally be mounted to one supply module.
- **Ease of servicing**
The signal lines are connected via plug-in terminal screws.
- **Power ratings by means of additional components**
Input power can be configured to meet the demands of the relevant application.

2.2. KDV 2.3 power ratings

It is possible to optimize usable KDV 2.3 to meet the requirements of an application by combining additional components.

(1)	(2)	(3)	(4)	(5)	(6)	(7)	(8)	Additional components	
$\frac{P_{DC}}{kW}$	$\frac{P_{KB-3}}{kW}$	$\frac{P_{KB-0.3}}{kW}$	$\frac{P_{BD}}{kW}$	$\frac{P_{BM}}{kW}$	$\frac{W_{max}}{kWs}$	$\frac{P_m}{kW}$	$\frac{S}{kVA}$	smoothing choke	additional capacitor
15	30	90	2	40	100	12	16	GLD 13	---
22	30	90	2	40	100	17,6	23	GLD 12	CZ 1.02
30	30	90	2	40	100	24	32	GLD 12	TCM 1.1-04
(1) P_{DC} = continuous DC bus power		(4) P_{BD} = continuous bleeder power		(5) P_{BM} = peak bleeder power		(6) W_{max} = maximum regenerative energy		(7) P_m = continuous mechanical power	
(2) P_{KB-3} = DC bus short-time power for 3 seconds (accelerating main drives)		(3) $P_{KB-0.3}$ = DC bus peak power for 0.3 seconds (accelerating servo drives)		(7) P_m = continuous mechanical power		(8) S = connected power			

Figure 2.2: Typical KDV 2.3 power ratings by combining additional components

2.3 KDV 2.3 - technical data

Designation	Symbol	Unit	KDV 2.3-100-220/300-000
Input - power section			
Nominal input voltage	U_{ACN}	V	3 x 230V (+10%; -15%) or 3 x 220V (+15%; -10%)
Frequency	f_N	Hz	50...60
Output - power section			
DC bus voltage	U_{DC}	V	300 (+ 15%; -10%)
Continuous DC bus voltage	P_{cont}	kW	30 (with add. capacitance 4 mF)
Peak DC bus power	P_{peak}	kW	90
Continuous bleeder power	P_{BD}	kW	2
Peak bleeder power	P_{BM}	kW	40
Max. regenerative energy	W	kWs	100
Power loss inside the control cabinet	P_v	W	150
Power loss outside the control cabinet	P_v	W	500 (+bleeder-continuous power)
KDV weight	m	kg	17
Weight of the mech. mounting accessories	m	kg	1.7
Weight of the LE3 blower	m	kg	4.2
Control voltage output			
+ 24 V on-load voltage	U_L	V	22 to 26
+ 24 VL continuous current	I_{UL}	A	11.5
+ 24 VL ripple		%	2
± 15 V measuring voltage	U_M	V	14.9 to 15.1
+ 15 VM continuous current	I_{+UM}	A	2
- 15 VM continuous current	I_{-UM}	A	2
± 15 VM ripple		%	0.1
Auxiliary voltage and blower power			
Input voltage	U_{AC}	V	230 (+10%;-15%)
Frequency	f	Hz	50 to 60
Auxiliary voltage power consumption	P	VA	500
Blower power consumption	P	VA	70 VA per heatsink
Blower voltage	U_{AC}	V	230V (+10%;-15%) or 115V(±10%) (depends on blower type)
Installation elevation without reduction of nominal data		m	1000 meters above sea level
Permissible relative humidity		%	maximum 95
Permissible absolute humidity		g/m ³	25 g water / m ³ air
Degree of contamination			- non-conductive contamination - no condensation
Protection classification:			
drive			IP 10 per DIN VDE 470, section 1
heatsink			IP 54

Figure 2.3: KDV 2.3 - technical data

3. Guidelines for installation and electrical connections



The following KDV 2.3 terminal diagram is a recommendation of the manufacturer of the unit. The circuit diagrams of the machine builder must be used for installation!

3.1. Terminal diagram

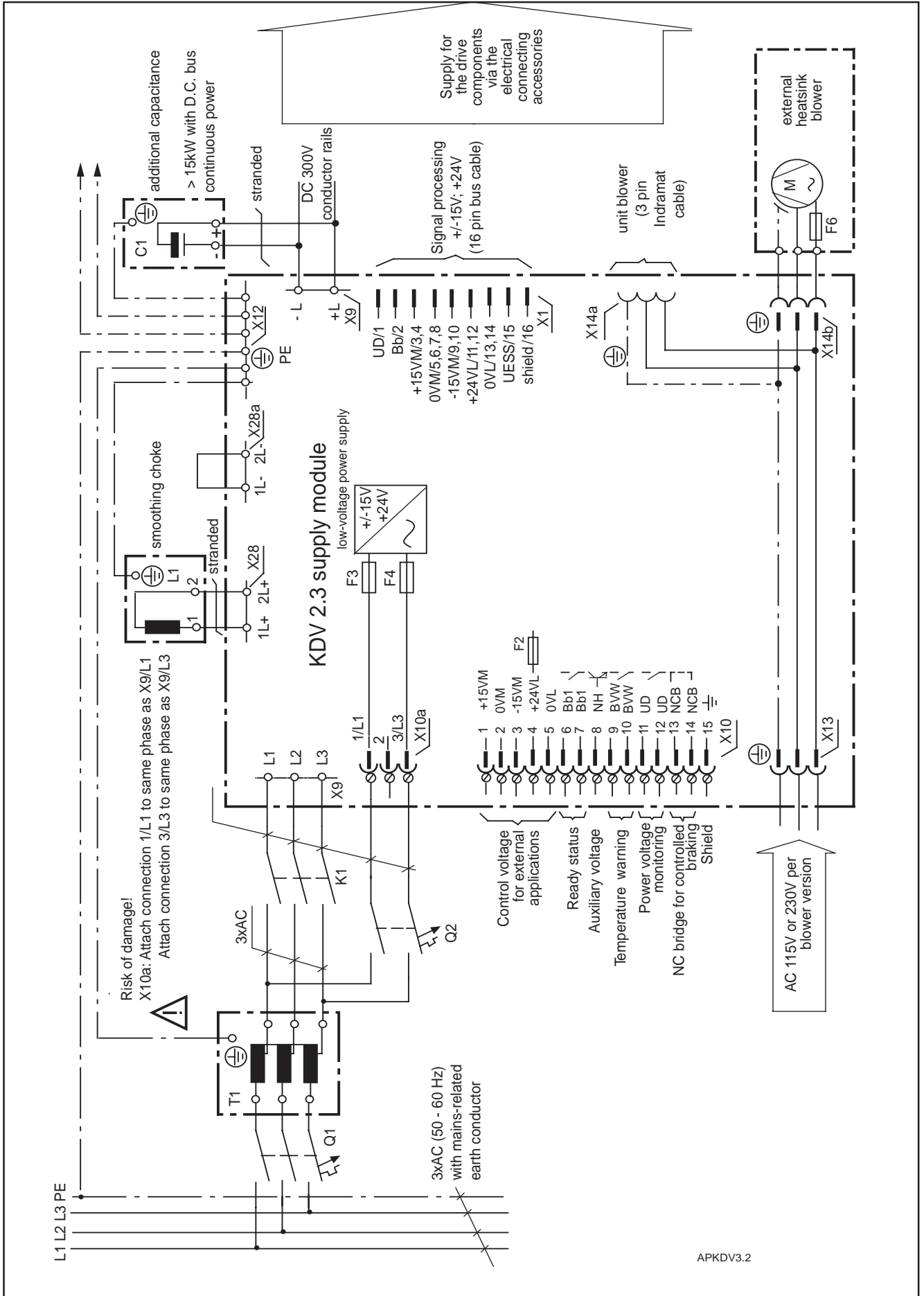

Figure 3.1: KDV 3.2 supply module connecting plan

3.2. Mains connection - power section

Connection voltage 3 x AC 230 V (+10%; -15%) or
3 x AC 220 V (+15%; -10%)

Frequency 50 to 60 Hz

Mains connection via transformer The mains voltage can generally be adapted by using an autotransformer (also see Section 3.5: "Requirements of the power supply system").

The KDV 2.3 can be directly connected to 3 x AC 220 V - power systems.

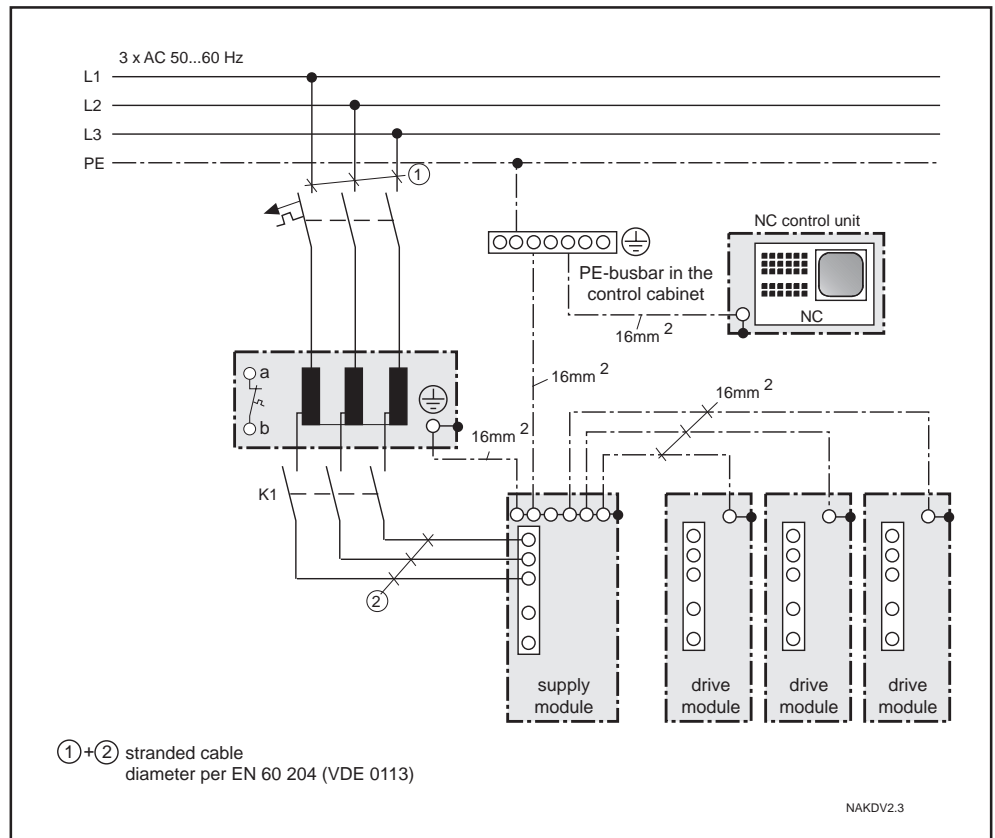

Figure 3.2: Connecting the KDV 2.3 to the mains via an autotransformer



Each drive module must be connected to the PE busbar of the KDV 2.3 by a separate ground conductor.

3.3. Fuse protection for the power connection

The KDV 2.3 mains connection can be protected by using either circuit breakers or gL classification fuses (slow-blow). Using power circuit breakers has the advantage that faulty operation, with two phases, for example, is not possible.

The protective device is generally placed on the primary side if a matching transformer is used.

Maximum permissible fusing

Mains voltage	Nominal voltage fuse (gL) / power circuit breaker		
	connected without matching transformer	connected with matching transformer primary side	connected with matching transformer secondary side
3 x AC 220 V	$I_N = 80 \text{ A}$	---	---
upto 3 x AC 240 V	---	$I_N = 80 \text{ A}$	$I_N = 80 \text{ A}$
upto 3 x AC 525 V	---	$I_N = 63 \text{ A}$	$I_N = 80 \text{ A}$

Figure 3.3: Maximum permissible fusing

If an INDRAMAT transformer is used and all connections are executed as outlined in section 3.2 then fuses and protective circuit breakers with a mains voltage of 3 x AC 400 V can be used (see table below).

Fuses for 3 x AC 400 V mains voltage

Transf. power (kVA)	Nominal (A) current		Recommended fuses of the gL type	Siemens power circuit breaker 3V.. ¹⁾ series	Setting range (A)	Setting range (A)
	primary	second.				
10	14.5	25.1	20 A slow-blow	3VU1300-•MP00	18 to 25	18
12.5	18.1	31.4	25 A slow-blow	3VU1600-•MP00	22 to 32	22
15	21.7	37.7	25 A slow-blow	3VU1600-•MP00	22 to 32	26
18	26.0	45.2	35 A slow-blow	3VU1600-•MQ00	28 to 40	32
20	28.9	50.3	35 A slow-blow	3VU1600-•MQ00	28 to 40	36
25	36.1	62.8	50 A slow-blow	3VU1600-•MR00	36 to 50	46
35	50.6	88.0	63 A slow-blow	3VF3111-5DN71	40 to 80	60

¹⁾ Maximum back-up fuse must be as per manufacturer's guidelines!

Figure 3.4: Fusing with 3 x AC 400 V mains voltage

3.4. Selecting the mains contactor

The following selection of transformers applies if power is connected on the secondary side of the mains transformer (as per KDV 2.3 terminal diagram). The choice must correspond to the nominal current of the secondary side of the mains transformer. Peak making currents need not be considered because of the KDV 2.3 charging current limitation.

Transformer power (kVA)	Secondary transf. nominal current (A)	Mains contactor from Siemens
10	25.1	3TF44
12.5	31.4	3TF46
15	37.7	3TF46
18	45.2	3TF47
20	50.3	3TF47
25	62.8	3TF47
35	88.0	3TF50

Figure 3.5: Selecting the mains contactor

3.5. Power supply requirements

Grounded threephase mains

Voltages can be adapted to grounded mains systems, either star systems with a grounded neutral or a system with a grounded phase (TN or TT mains), by using an autotransformer. The KDV 2.3 can be directly connected to 3 x AC 220 V mains.

Ungrounded threephase mains

There is the increased danger in ungrounded mains (IT mains) that overvoltages can occur between phases and housing. The KDV 2.3 should only be operated with such systems, if:

- it is connected across an isolation transformer, or,
- the installation is protected with an overvoltage conductor.



Connecting the KDV 2.3 via an isolation transformer offers the best protection against overvoltage and the greatest operating safety!

Permissible overvoltage levels

The voltage levels between the outer conductors (L1, L2, L3, 1L1, 3L3) and the KDV 2.3 housing can equal 230 V (effective).

Non-periodic overvoltages per VDE 0160 between phases and housing are permissible for the KDV 2.3 (see following diagram).

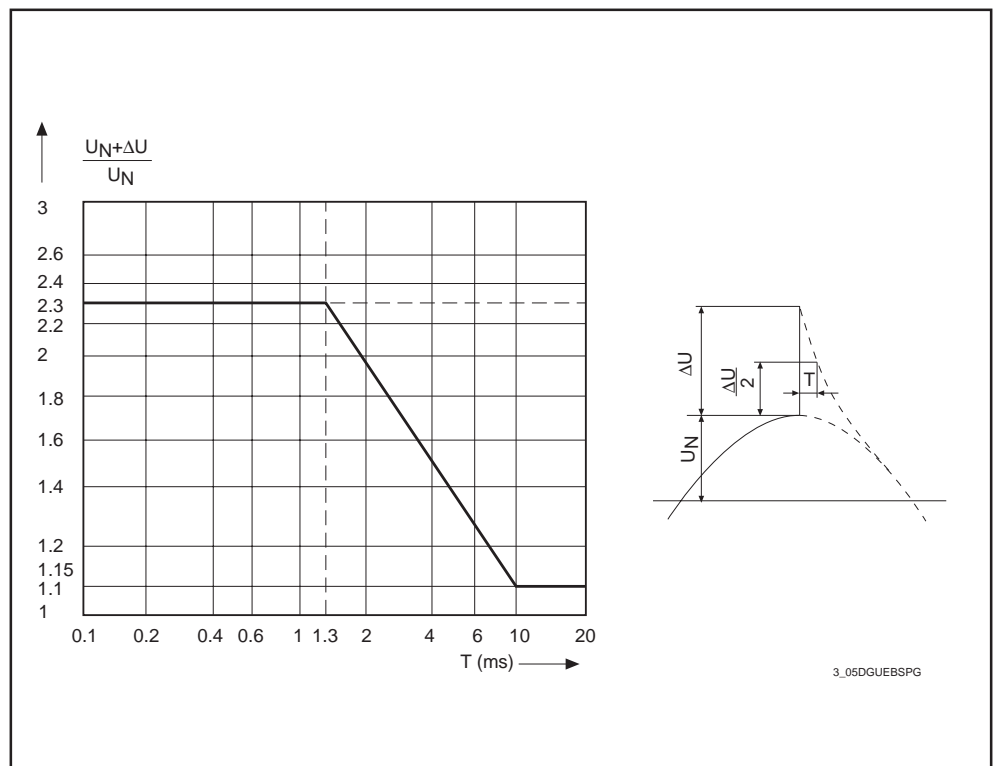

Figure 3.6: Permissible non-periodic overvoltages per VDE 0160

The KDV 2.3 can be connected to 3 x AC 230 V - input power systems. This means that the maximum permissible, non-periodic overvoltage may equal: $230 \text{ V} \times \sqrt{2} \times 2.3 = 745 \text{ V}$.

3.6. DC bus

Use the busbars found in the connection accessories of the drive module to connect the drive modules to the DC bus of the KDV 2.3. Use individual cables with stranded wires for longer connections (maximum length is one meter).

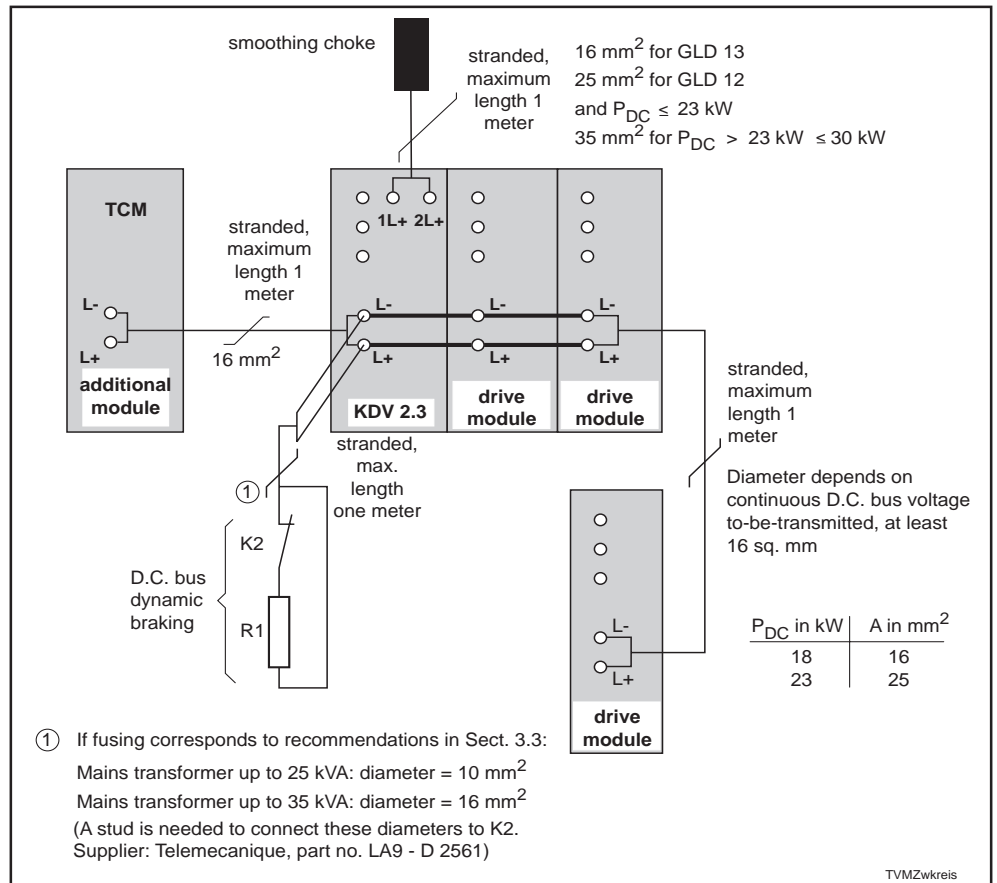

Figure 3.7: DC bus wiring



During normal operation, the dynamic brake resistor R1 has DC 300 V applied to it with respect to ground! The cabinet builder must provide protection against accidental contact (plexiglass or perforated sheeting, for example).

3.7. Additional capacitance on the DC bus

It is possible to connect additional capacitors (CZ 1.02) or additional capacitance modules (TCM) to the DC bus to increase the capacity of the KDV 2.3.

Increasing power An additional capacitance of 4 mF is needed to utilize this.

Energy capacitor for power failures In a few applications, it might be necessary for the drives to back up in the event of a power failure. The energy stored in the DC bus can be used for this action.

The DC bus capacity can be increased with the use of additional capacitors. A maximum of 8 mF additional capacitors may be connected. Each mF of additional capacitance can store up to 30 Ws.

3.8. Smoothing choke

The KDV 2.3 must be operated with a smoothing choke in the "L+ line" from a DC bus load of 9Kw:

DC bus load	Smoothing choke required (see Section 7.6 for technical data)
up to 9 kW	none
up to 15 kW	GLD 13
greater than 15 kW	GLD 12

Figure 3.8: Required smoothing choke

3.9. Electronics and internal blower power supply

Electronics supply

Supply terminal:	X10a/1 - X10a/3
Terminal diameter:	maximum 1.5 mm ²
Terminal voltage:	AC 230 V; 50 to 60 Hz
Terminal capacity:	500 VA (if electronics supply reaches maximum load)
Recommended fusing:	Circuit breaker 10 A (tripping characteristic C: magnetic release between 7 to ten times rated current)



Tap electronics power off of outer conductors L1 and L3 of the power source (see terminal diagram in Section 3.1). NOTE: X10a/1 and X9/I1 must have the same phase, and X10a/3 and X9/L3 must also have same phase! The KDV 2.3 could otherwise be damaged!

External blower supply

Supply terminal:	X13
Terminal diameter:	maximum 1.5 mm ²
Terminal voltage:	LE3-220 blower: AC 220/230 V; 50 to 60 Hz LE3-115 blower: AC 110/115 V; 50 to 60 Hz
Terminal capacity:	70 VA for each blower

3.10. Wire-ribbon connection for the electronics and signal exchange

The wire-ribbon connection X1 has two functions:

- supplying power to the drive electronics, and,
- signal exchange between the supply and drive modules.

The wire-ribbon cable is part of the connecting accessories of the drive module.

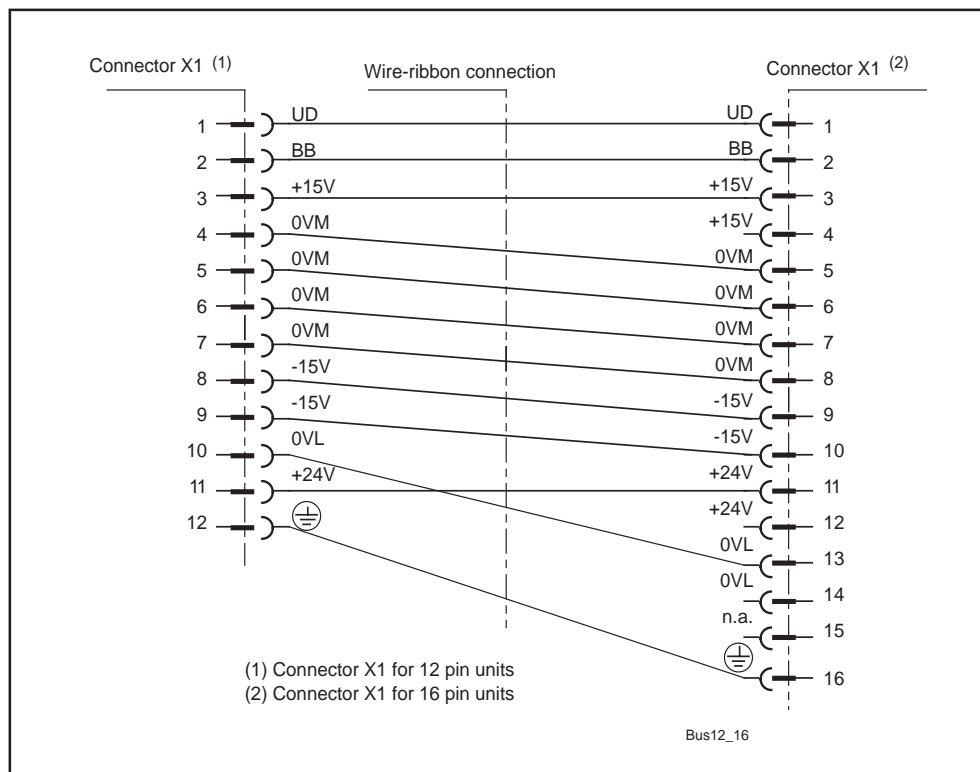

Figure 3.9: Wire-ribbon for transition from 12-pin to 16-pin connector

The wire-ribbon connection receives a terminal connector. It is used to verify the connections. This terminal connector is part of the KDV 2.3 mounting accessories. If no terminal connector is installed, the Bb1 contact of the power supply will not close.

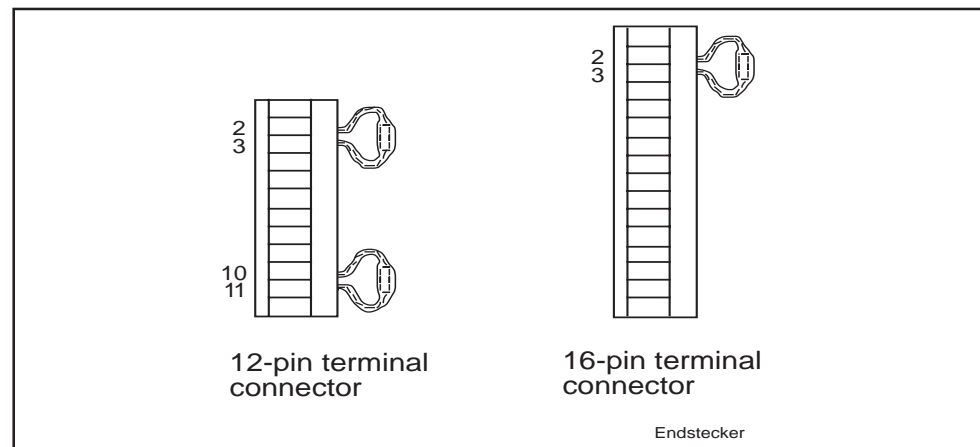

Figure 3.10: Terminal connector for the wire-ribbon connection

3.11. Fault current protective device

Discharge current Capacitive discharge currents always flow to earth in switch-mode drive controllers.

The extent of the discharge current is dependent upon:

- the number of drive controllers used,
- the length of the motor power cable, and,
- the ground conditions at installation site.

The discharge current is unavoidably increased, if measures are taken to improve the electromagnetic compatibility (EMC) of the machine (mains filter, shielded cables).

FI-current limiting type circuit breakers with a nominal fault current of less than 0.3 A should **not** be used!

The switching on of inductors (transformers, contactors, electromagnetic valves) can cause false tripping.



The safety of electronic equipment with threephase bridge connections (B6 switches) cannot be guaranteed if commercial, pulse-current sensitive FI protective circuit breakers are used. For this reason, FI circuit breakers should not be the only safety measure taken.

3.12. Checking the control cabinet



Only those voltages outlined in the data sheets or in the interface descriptions should be connected!

Before performing any high voltage test on the cabinet, remove all connections to the KDV 2.3!

3.13. KDV 2.3 from the front

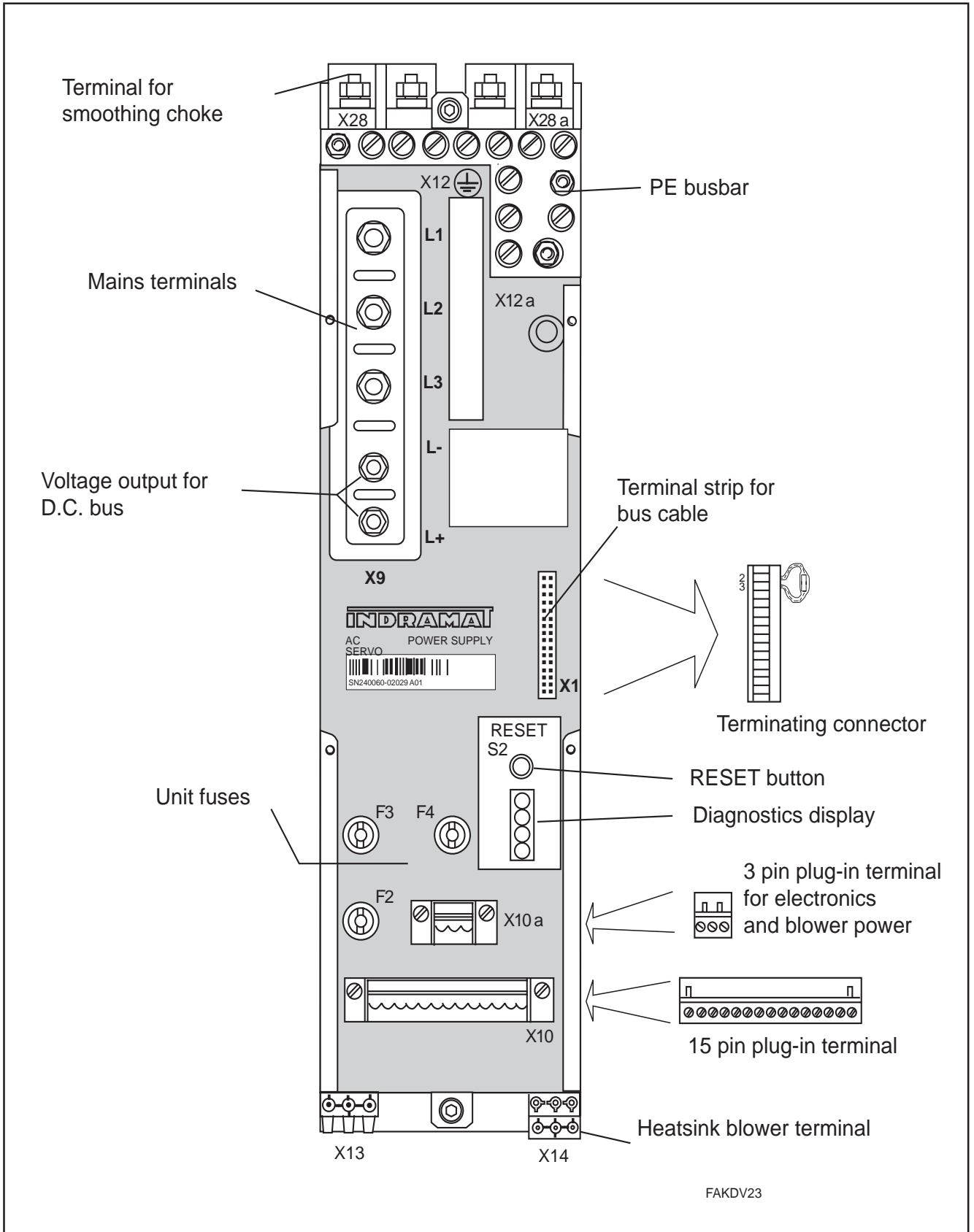

Figure 3.11: KDV 2.3 from the front

3.14. Installing the KDV 2.3 in the control cabinet

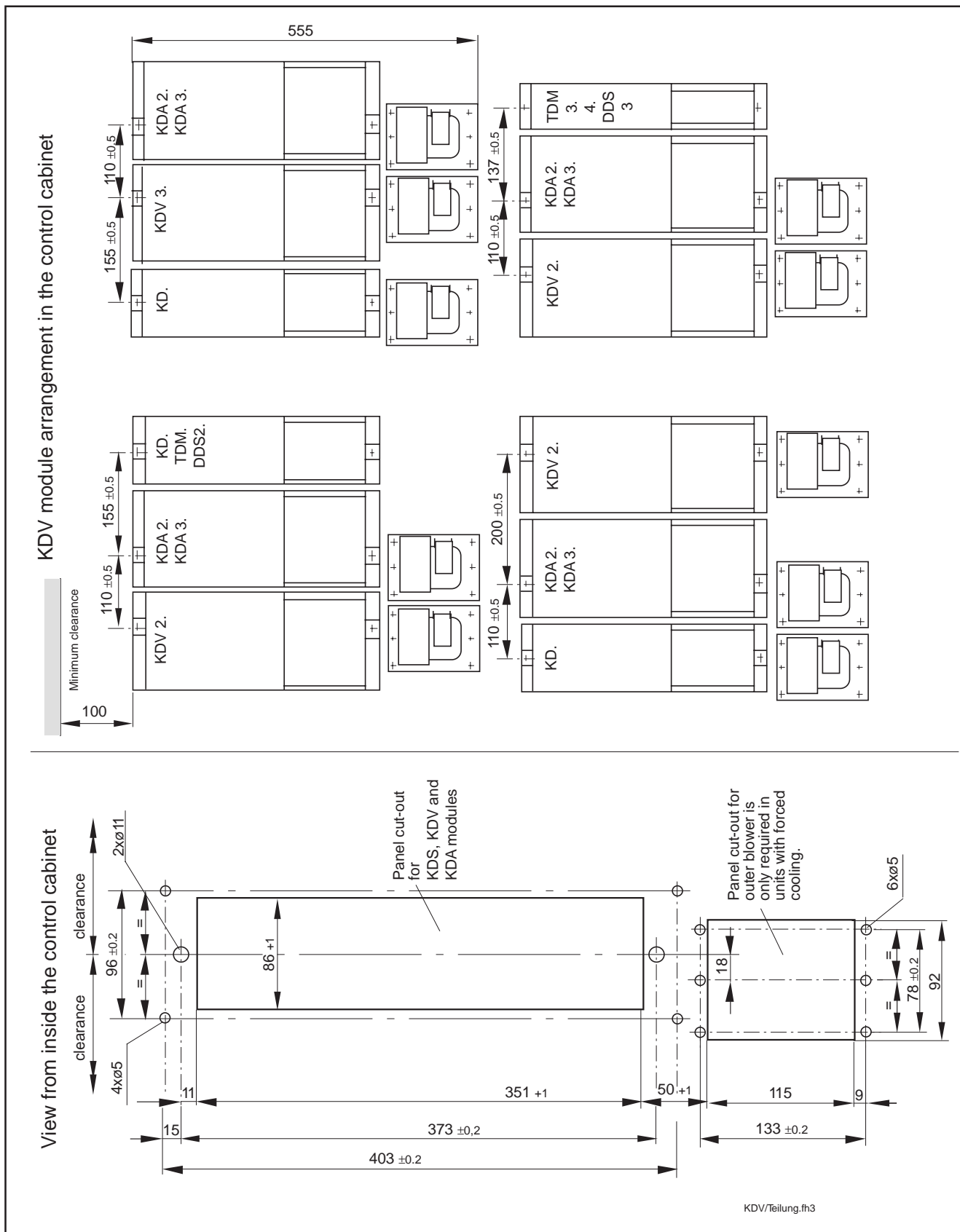

Figure 3.12: Panel cut-outs and dimensions

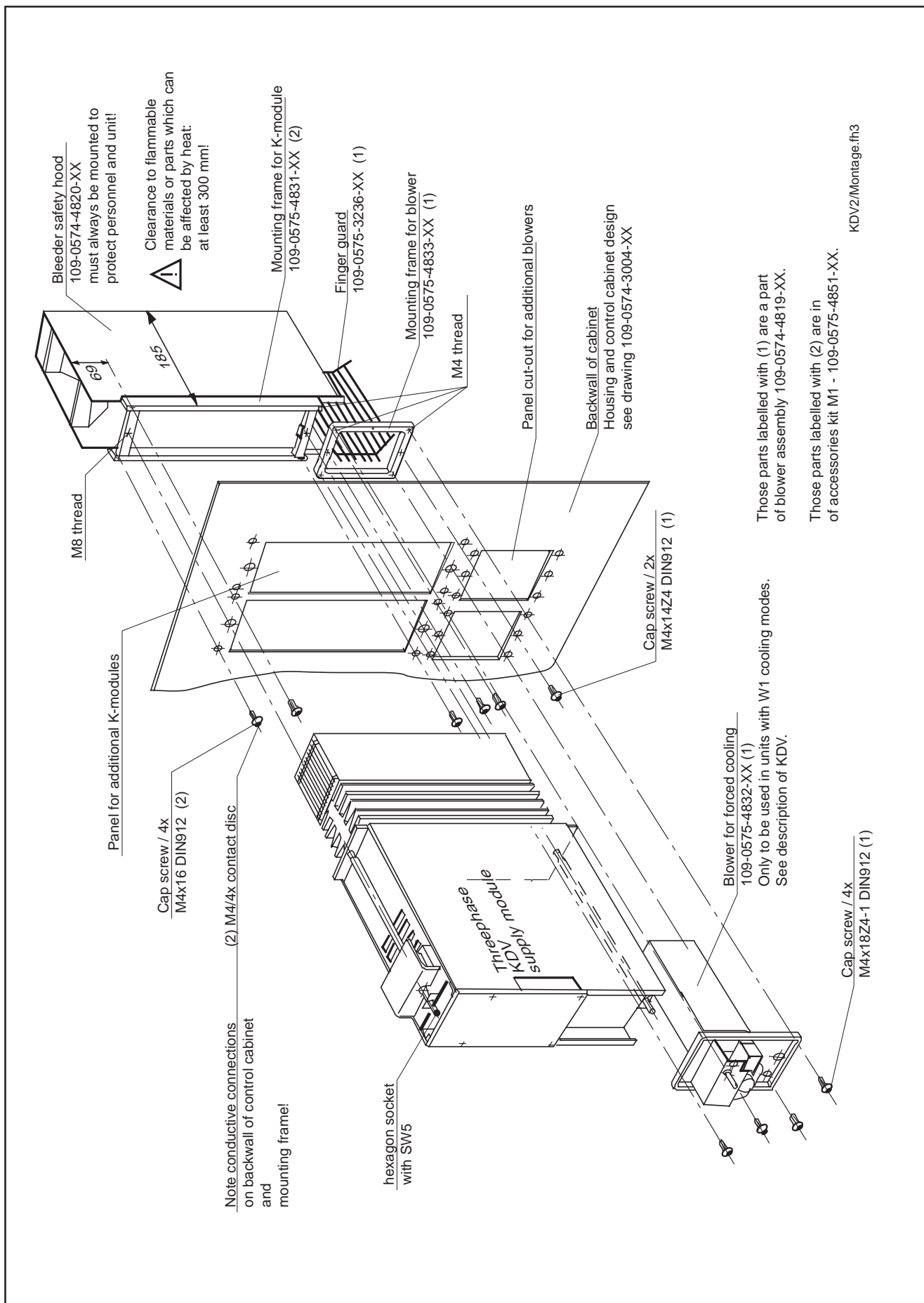

Figure 3.13: Mounting the KDV 2.3 into the control cabinet

Heat loss Heat loss occurs when the KDV 2.3 is operated. This is caused by basic losses during signal voltage generation, power losses and by energy transformation in the bleeder.

The heatsink, which conducts this heat loss, is mounted to the back of the KDV 2.3. This means the KDV 2.3 is mounted with the heatsink sticking out of the back of the control cabinet.



Note that the heatsink must maintain a safety clearance of 30 cm from flammable materials or parts which could be affected by heat!

Heat loss in the control cabinet

The heat loss occurring within the control cabinet can be reduced to about 150 W with the above mounting mode. This means that more compact control cabinets can be built. It also eliminates or minimizes the additional work due to control cabinet air conditioning.

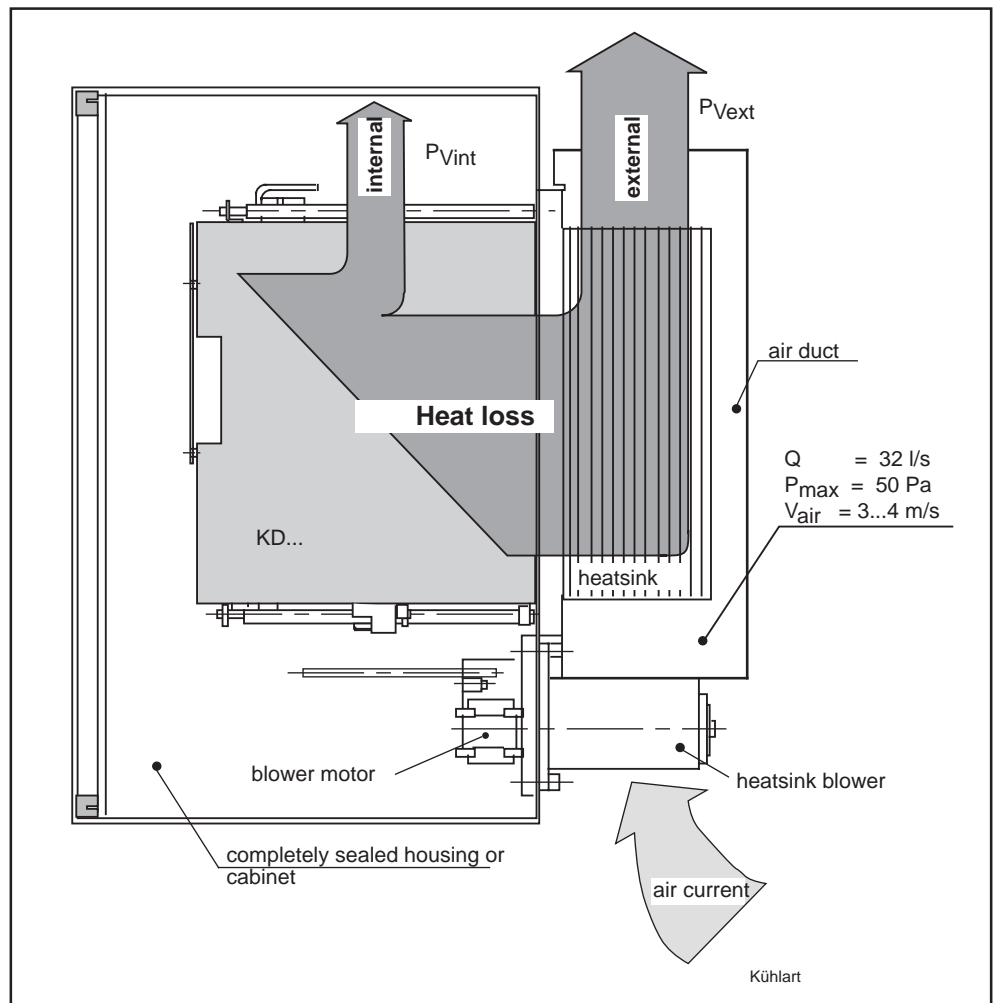

Figure 3.14: A break down of the heat losses

Cooling with a heatsink blower

A bleeder cover SH-KD ist needed for the air duct and to cover the bleeder. The heatsink blower can be ordered, with accessories, using order no. LE3... (LE3-220 with 220 V, LE3-115 with 115 V).

Cooling with a central blower

If several heatsinks are cooled in a common air duct with only one central blower used, then make sure that there is sufficient air! Check air stream Q!

4. Control circuits (control of input power)

The control circuits relate to

- switching input power on and off, and,
- the E-Stop.

The control circuits INDRAMAT recommends illustrate the operating principle. Several different control circuits are suggested in this section.



The control scheme selected and its effect depends on the features and timing of the entire machine and is the responsibility of the machine builder.

4.1. Differentiating features of the power circuits

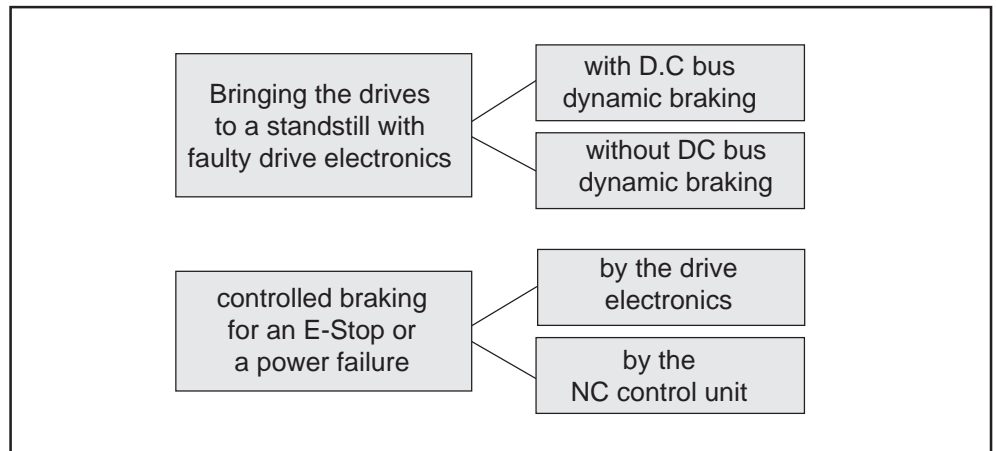

Figure 4.1: Differentiating features of the power circuits

Bringing the drives to a standstill with an error in the drive electronics or without DC bus dynamic braking

DC bus dynamic braking is an additional safety factor when braking the drives to a standstill in the event of a fault in the drive electronics.

Synchronous motors are always braked to a standstill with *DC bus dynamic braking* regardless of whether the drive electronics are functioning or not.

Asynchronous drives do not brake when DC bus is short-circuited!

Without dynamic braking synchronous motors will coast uncontrolled if the drive electronics are not functioning.

Controlled braking of the drives with an E-Stop or power failure with command-to-zero, or position controlled by the NC control unit

The drive control brings the drives to a standstill for an E-stop or as a result of a power failure.

In the event of an E-stop or if the drive-internal monitor is tripped, the drive control will switch velocity to zero. The drives brake uncontrolled at maximum torque.

It is necessary with some applications (e.g., electronically-coupled gear cutting machines) that the NC control unit brings the drive to a standstill in an E-stop or in the event of a power failure.

The drives are braked to a standstill by the NC control unit in the event of an E-stop or if the drive-internal monitor is tripped.

4.2. Using the DC bus dynamic brake



The best way to bring the drives to a standstill with a fault depends on the drive equipment used and the features of the machine. The following recommendations should, therefore, only be viewed as a support for the machine builder.

The machine manufacturer is fully responsible for the features and the scope of the individual safety mechanics!

The DC bus dynamic brake is intended to protect the machine. A few typical (fault) situations are used in this section to explain when the DC bus dynamic brake should be used.

The following (fault) situations serve as examples:

- Bb1 contact open
- limit switch open
- following error signal from the NC control unit
- E-stop actuated
- light barrier, safety door or step-pad contact activated
- operator enable switch ("dead man key") is deactivated

Bb1 contact open

The Bb1 contact of the KDV 2.3 opens in the presence of an error in the drive electronics or interrupted feedback lines. In this case, synchronous drives can only be braked to a standstill by the DC bus dynamic brake! Short-circuiting the DC bus will not brake asynchronous drives. Mount additional safety devices if necessary!

Limit switch activated

Limit switches are activated by the NC control unit or drive errors. For this reason, the DC bus dynamic brake should be used. The overtravel distances set (limit switch for the machine limit stop) must therefore be greater than the braking path needed. Short-circuiting the DC bus will not brake asynchronous drives. Mount additional safety devices if necessary!

Following error message from the NC control unit

This message indicates a fault in the drive. The DC bus dynamic brake should be used in this case for this reason. Short-circuiting the DC bus will not brake asynchronous drives. Mount additional safety devices if necessary!



Dynamic braking is not required for the above errors, if a coasting of the drives cannot damage the machinery. Motors with mechanical holding brakes can be an alternative.

E-Stop button, light barrier, safety door, step-pad contacts tripped or pendant enable deactivated

These monitoring devices serve to protect personnel. The drive equipment of the machine must be taken into consideration for the error responses in this case:

Machines with modular asynchronous drives

The danger caused by a main spindle drive of a tooling machine coasting uncontrolled (usually asynchronous drives) is greater than the danger from the uncontrolled coasting of a feed drive (usually synchronous drives).

If the referenced monitoring devices are tripped, then both the mains contactor and the drive enable signal should be switched off. The DC bus voltage must not be short-circuited because asynchronous drives cannot otherwise be braked to a standstill.

Machines with modular synchronous drives (e.g., handling systems)

Switching off the mains contactor and removing the drive enable achieves the shortest possible braking distances with intact drives. Only if the energy stored in the DC bus capacitors can initiate dangerous drive movements, must the dynamic brake be used with a fault.

Pendant enable button



Dynamic brake contactors and resistors are not suited for jogging. The control cabinet could be damaged if this is ignored!

Input signal	Existing drive equipment			Recommended response	
	modular asynchronous and synchronous drives	only modular synchronous drives	only modular asynchronous drives	DC bus dynamic brake activated	drive enable and mains contactor OFF
Bb1 contact open	●	●		●	●
			●		●
Limit switch open	●	●		●	●
			●		●
Following error signal from the NC	●	●		●	●
			●		●
E-stop button pressed	●	●	●	1)	●
Light barrier, safety doors, step pad actuated	●	●	●	1)	●
Pendant enable button deactivated	●	●	●	1)	●

1) Only if dangerous drive movements can be triggered by energy still present in the DC bus capacitors.

Figure 4.2: When to use the DC bus dynamic brake

4.3. DC bus short-circuiting switch

The DC bus short-circuit switch recommended by INDRAMAT is conceived to protect either machine or plant against damage in the event of a drive failure. This can be used to brake motors with permanent magnetic excitation even in the event of drive control failure. This function cannot, however, be the only safety device used to protect personnel.

Circuit design This DC bus short-circuit contactor can switch the "short-circuit current" on but not off. The DC bus short-circuit contactor may not be re-applied, once released, until the DC bus has discharged. The following recommended circuits (section 4.4) will make interference-free operations possible. Programming the PLC appropriately does not guarantee the correct switching sequence. The varying contactor actuating times can possibly trigger the mains contactor before the DC bus short-circuit contactor is opened. This means that the mains contactor should additionally be locked by means of an auxiliary contact of the DC bus short-circuit contactor.



DANGER

The DC bus short-circuit resistor is not secured against accidental contact. There is the danger of high-voltages (greater than 50 V).

Electrical shock resulting from contact

==> use an appropriate cover, see that it is in place or properly mounted



CAUTION

Thermal damage caused by DC bus short-circuit contactor and resistor in the event of faults in the control or contactor is possible.

Damage or loss due to fire is possible inside the control cabinet.

==> use an appropriate cover, see that it is in place or properly mounted

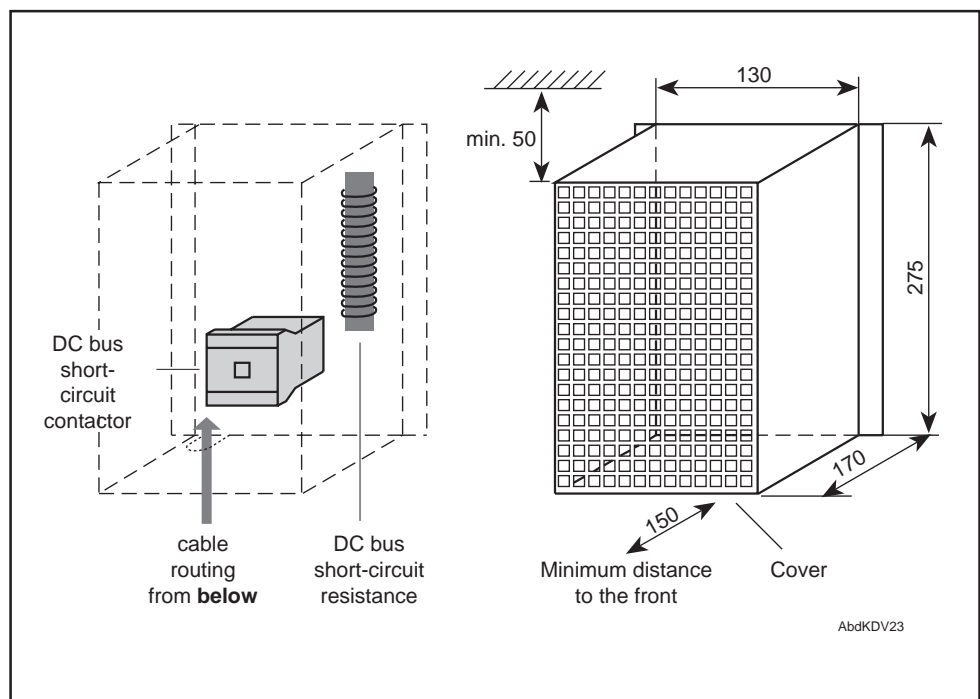

Fig. 4.3: Suitable covers and unit arrangements for the DC bus short-circuit

Switching frequency A maximum of six switching procedures is permitted per minute.

The number of possible switching sequences is reduced if the sum of the rotary drive energy and the energy stored in the additional capacitance is greater than 1500 Ws. Otherwise, the DC bus short-circuit resistor will be overloaded. The number of the permissible DC bus short-circuit actuations can be calculated as follows:

$$S = \frac{1500 \text{ W} \cdot 60 \frac{\text{s}}{\text{min}}}{(W_{\text{rot}} + W_{\text{ZK}})}$$

- S = number of permissible actuations per minute (max. 6)
 W_{rot} = energy content of the drive given in Ws
 W_{ZK} = energy stored in the additional capacitance given in Ws

Service life The DC bus circuit contactor has a service lifespan of 20,000 actuations.

Maximum drive torque Once the DC bus is short circuited, the drive will be decelerated with the short-circuit torque. This torque may be higher than the maximum torque indicated in the selection list. Particularly, if the relationship maximum torque to short-term operating torque is less than 1.3, then there will probably be increased torque.



Increased torque with short-circuited DC bus is possible.

Damage to mechanical transmission parts, machine damage from dimensional shifting that has gone unnoticed.

==> mechanical transmission elements must be laid out in terms of the torque at with a short-circuited DC bus.

A list of the short-term torque for MDD motors can be requested. The following formula can be used to calculate maximum torque with a short-circuited DC bus.

$$M_{\text{ZK}} = \frac{K m^2 \cdot \omega}{\sqrt{(R_A + R_{\text{ZK}})^2 + (\omega p L_A)^2}}$$

$$M_{\text{maxZK}} = M_{\text{ZK}} + M_H$$

- M_{maxZK} = max . drive torque with short-circuited DC bus
 M_{ZK} = short-circuit torque in Nm
 M_H = decel torque of the holding brake in Nm
 Km = current torque or voltage constant in Vs/rad
 ω = angle speed in rad/s
 R_A = winding resistance of the motor in Ω
 R_{ZK} = DC bus short-circuit resistance in Ω (2.2 Ω)
 p = number of pole pairs; for MAC and MDD the following applies:
 size \leq 41; $p = 2$
 size \geq 63; $p = 3$
 L_A = winding inductance of the motor in H

4.4. KDV 2.3 control circuits with dynamic braking

Application Modular synchronous motors are used.

This control circuit achieves a high degree of safety **at low cost**. The monitoring capabilities built into the drive system are most effectively implemented.

Typical applications:

- the KDV 2.3 is only supplying feed drives, and,
- if asynchronous main drives and feed drives are being operated by the same KDV 2.3.

Features Dynamic braking always stops synchronous motors whether the drive electronics are functioning or not.

Dynamic braking is only activated for **drive faults**. If the E-stop monitor is tripped, then drives are stopped under drive regulation at maximum torque.

There is a **controlled braking of the drives under drive regulation** at maximum torque with either an E-stop, or if the KDV 2.3 monitors are triggered (e.g., as the result of a power failure).



The NC bridge (X10/13 - X10/14) must not be closed!

Operation The mains contactor drops out immediately when the E-stop button is pressed. An auxiliary contact on the mains contactor switches the drive enable signal off. Drive internally, the velocity command is switched to zero in all drives. There is a controlled braking of all drives.

A drive fault message from the KDV 2.3 (Bb1 contact), a fault signal from the NC control unit (servo error), or the tripping of an axis travel limit switch results in the mains contactor being switched off and the activation of dynamic braking.

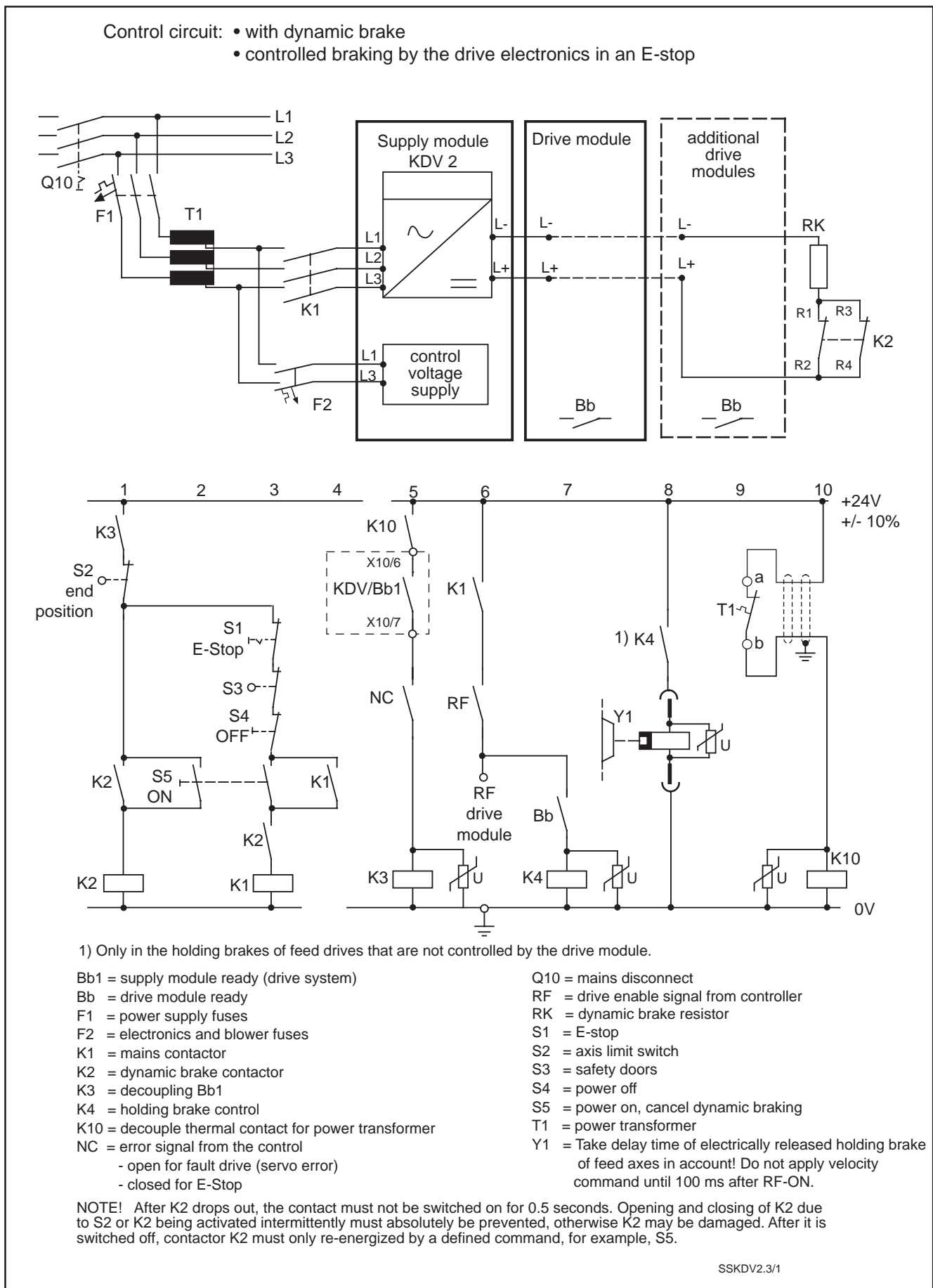

Figure 4.4: Control circuits without soft-start resistor with dynamic braking

4.5. KDV 2.3 control circuits without dynamic braking

Application When an uncontrolled coasting of the drives cannot damage the machine.

Typical applications:

- if the KDV 2.3 supplies only asynchronous drives, and,
- if the end position of the feed axis has been sufficiently damped.

The DC bus voltage is not short-circuited. Asynchronous drives are not braked by dynamic braking in the presence of a drive fault. There can be no controlled braking of the drives if the dynamic brake is applied.

Features There is a **controlled braking of the drives under drive regulation** at maximum torque with either an E-stop or if the KDV monitors are tripped.



The NC bridge (X10/13 - X10/14) must not be closed!

Operation The mains contactor immediately drops out when the E-stop button is pressed. An auxiliary contact on the mains contactor switches the drive enable signal off. Drive internally, the velocity command is switched to zero in all drives.



Dynamic braking can only be dispensed with if the uncontrolled coasting of the drives cannot damage machinery.

Motors with mechanical holding brakes can be an alternative.

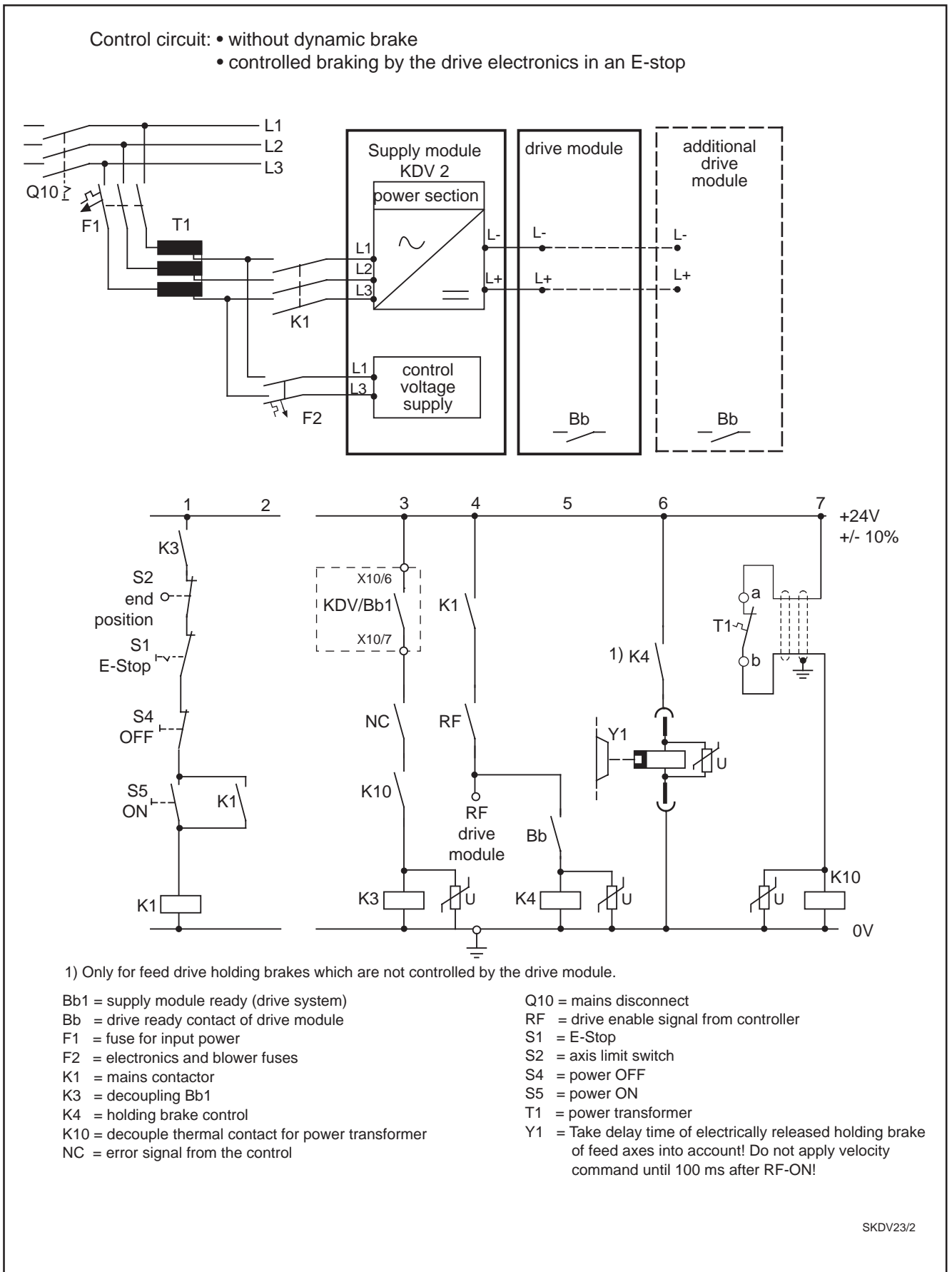

Figure 4.5: Control circuits for KDV 2.3 without dynamic braking

4.6. Control circuits for a controlled braking of the drives for an E-stop or power failure

Application For those drives coupled as an electronic drive via the NC control, and which cannot accept a phase-angle error with a power failure or an E-stop.

Features The DC bus voltage is not short-circuited. This means that power is available for a controlled braking of the drives.

The energy stored or regenerated in the DC bus must be greater than the energy required to energize asynchronous drives or to execute a return action.

For an E-stop or if a KDV monitor is tripped, drives are **stopped by the NC control unit under drive regulation**.



The NC bridge (X10/13 - X10/14) must be closed!

The mains contactor must not be permitted to switch off the drive enable signal of the drives !

Operation The mains contactor is immediately switched off when the E-stop is tripped. There is a controlled braking of the drives by the NC control unit.



When the NCB contacts are jumpered, the signal for command-to-zero will be suppressed if there is a power fault. The superordinate control must assure that the drive is stopped. This high priority control must monitor the UD contact of the KDV 2.3 and bring the drive to a halt whenever the contact should open.

There will otherwise be an uncontrolled coasting of the drives if the power supply is faulty!

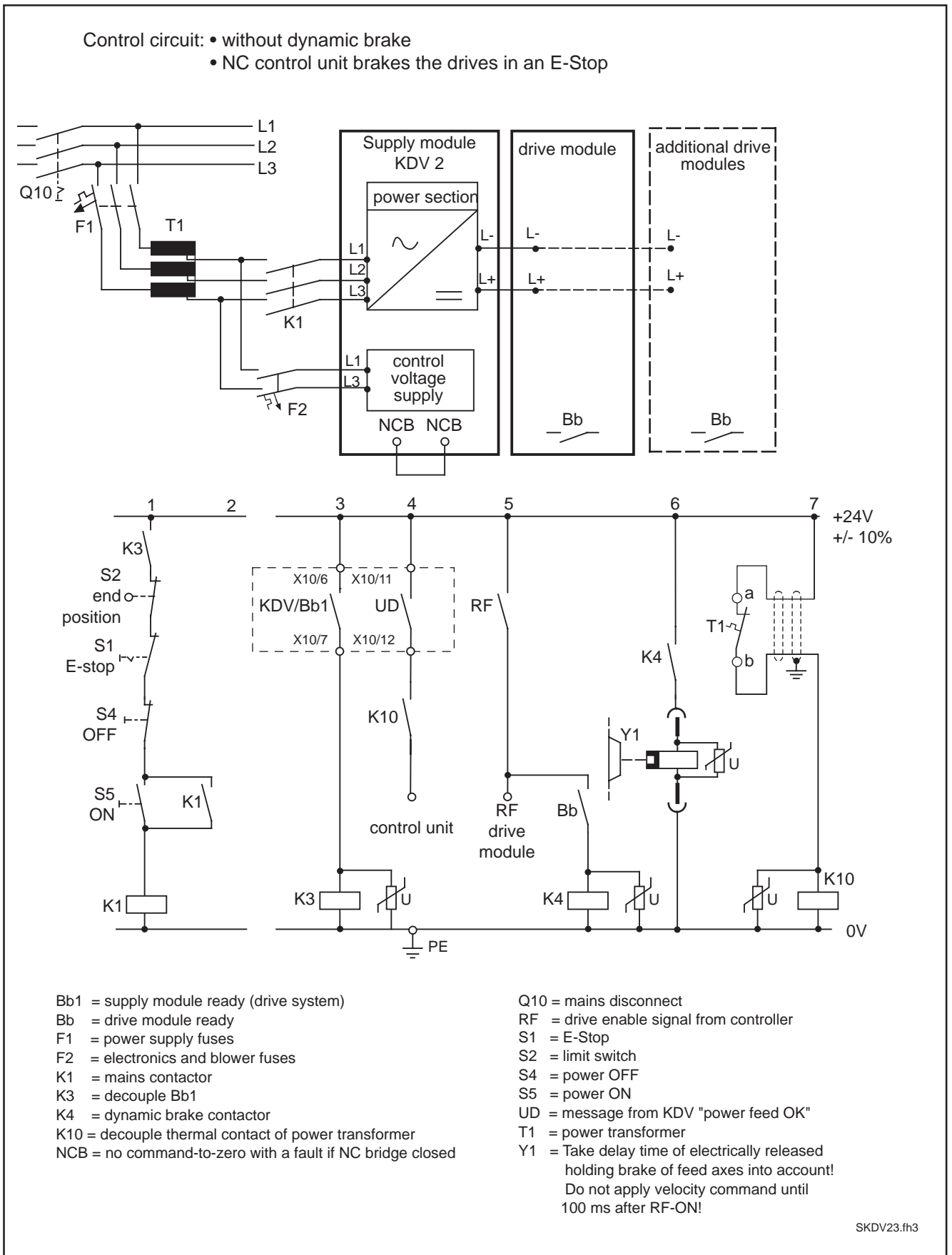

Figure 4.6: Control circuits for a controlled braking with an E-Stop or power failure

5. Interface descriptions

5.1. Signal voltages

Signal voltages The signal voltages can be tapped off of terminal strip X10. These terminals are for measuring and test purposes. If these voltages are used out of the KDV, then make sure that no interference voltages are coupled in (use short, shielded cables).

Do not exceed the load capacity of the signal voltage outputs to ensure proper operation of the drives! The $\pm 15 V_M$ are short-circuit-proof. The $+24V_L$ are protected by fuse F2.

Terminal	Voltage	Note
X10/1	$+15V_M$	maximum measuring voltage 100 mA
X10/2	$0V_M$	measuring voltage reference potential
X10/3	$-15V_M$	maximum measuring voltage 100 mA
X10/4	$+24V_L$	maximum load voltage 2A
X10/5	$0V_L$	load voltage reference potential

Figure 5.1: Signal voltages on X10

5.2. Ready

Bb1 contact Output Bb1, terminal X10/6 - X10/7
Potential-free contact, maximum load DC 24V/1A

Operating status:	no power to the electronics	fault in the KDV 2.3 or in the drive	ready
Output	open	open	closed



The Bb1 contact of the KDV 2.3 has a superordinate significance. The E-stop chain of the drive system is tied into the Bb1 contact. Only when it is closed may threephase AC power be applied!

The Bb1 contact closes when power for the electronics is applied to X10 and there is no fault.

The Bb1 contact opens for the following faults:

- tachometer fault
- overtemperature in the drive modules
- drive module bridge fuses
- a fault in the $\pm 15V_M$ / $+24V_L$ signal voltages
- an open wire-ribbon connection or missing termination connector
- the heatsink temperature of the KDV 2.3 is too high
- ground short in drive system
- bleeder overload

5.3. Electronics supply working

Output NH Transistor output NH, terminal X10/8
Maximum load DC 24V/100mA

Operating status:	no power to the electronics	fault in auxiliary voltage, DC bus voltage functional	auxiliary voltage functional
Output	high-resistance	low-resistance	high-resistance

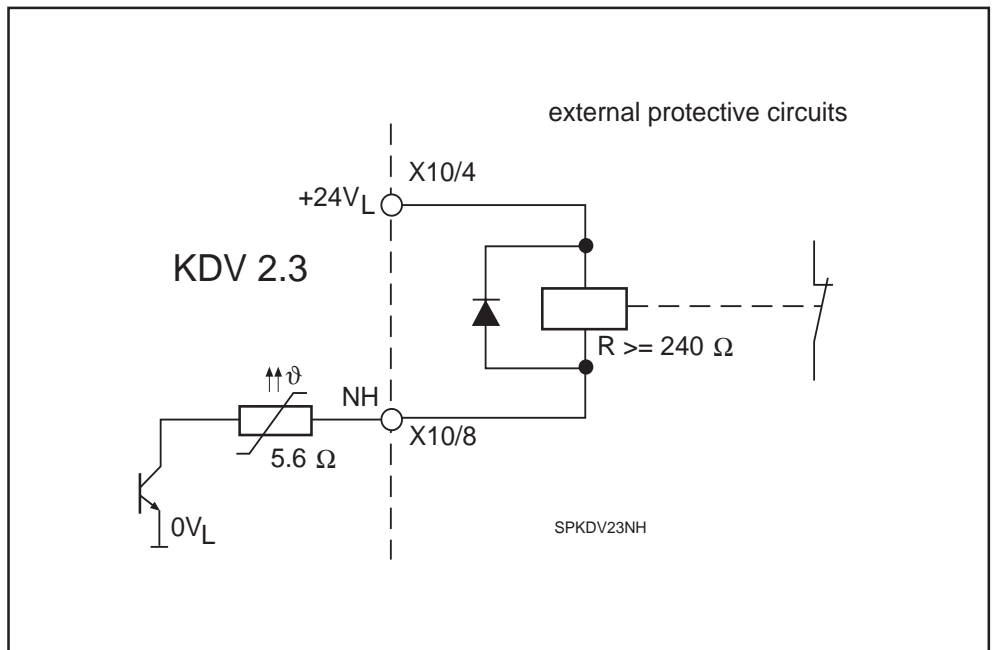

Figure 5.2: Protective circuit of the NH transistor output

5.4. Feedback power too high

BVW contact Output BVW, terminal X10/9 - X10/10
Potential-free contact, maximum load DC 24V/1A

Operating status:	no power to the electronics	feedback power	
		too high	acceptable
Output	open	open	closed

The bleeder warning contact opens if feedback power is greater than 80% of continuous bleeder power. If the bleeder load should continue to rise to the point of thermal overload, then the Bb1 contact will interrupt power flow. The response of the drive system to this fault depends on the "NC" bridge (see section 5.6).

5.5. Power supply working

UD contact Output UD, terminal X10/11 - X10/12
Potential-free contact, maximum load DC 24V/1A

Operating status:	no power to the electronics	power supply	
		faulty	functional
Output	open	open	closed

The UD contact acknowledges that the power supply system is working.

It opens for the following faults:

- mains or phase failure, or,
- the DC bus voltage is less than 200 V

The response of the drive system to these errors depends on the NC bridge (see section 5.6).



If an NC controlled braking becomes necessary, then the drives must be braked to a standstill by the superordinate NC control unit when the UD contact opens!

5.6. Bringing the drives to a standstill with a fault in the power supply system

NC bridge NC bridge, terminals X10/13 - X10/14

Open Given a fault in the power supply and within the drive systems, the velocity command of all connected drives is switched to zero if the NC bridge is open. The drives are braked at maximum torque. In the presence of a drive fault, the Bb1 contact additionally switches off the power.

Closed If the NC bridge is closed, then the command-to-zero is suppressed with the following faults:

- fault in the power supply system
 - mains or phase failure
 - DC bus voltage less than 200V
- drive fault
 - an open wire-ribbon connection or missing termination connector
 - the heatsink temperature of the KDV 2.3 is too high
 - ground short in the drive module
 - bleeder overloaded

This makes it possible for the NC control unit to brake the drives to a standstill with either a mains or phase failure. The power regenerated during braking must be greater than the power consumed.

The Bb1 contact always switches the power supply off with a drive fault.



The superordinate control must guarantee that the drives are braked with a closed NC bridge because the command-to-zero is dropped. The superordinate control monitors the UD contact and brings the drives to a standstill once the contact is open.

There will otherwise be an uncontrolled coasting of the drives if the power supply system fails.



Do not use an NC bridge in digital drives with SERCOS interface. The programmable error reaction of digital drives means a controlled braking is possible without the bridge. The bridge prevents the signal to the drive indicating there is a fault in the power supply.

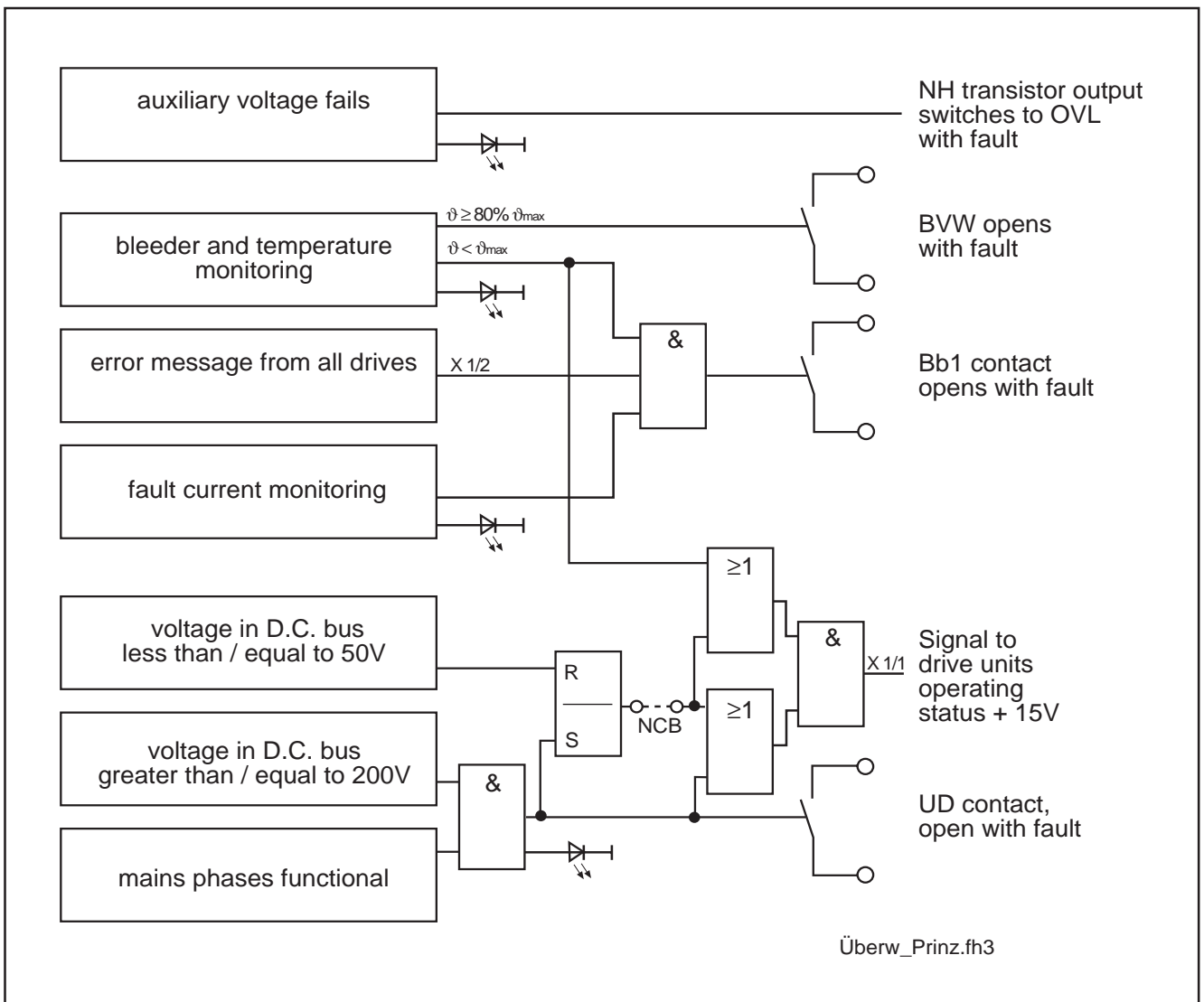

Figure 5.3: Diagram of interfaces for monitoring and diagnostics systems

6. Troubleshooting guidelines

Lengthy troubleshooting and repair to drive components on the machine are not acceptable because of the resulting production down-time.

Thanks to their construction, INDRAMAT AC drives enable individual functional units to be easily and completely replaced without the need for tuning.

This means servicing is limited to fault-location either in the motor, the power supply module or the drive in the event of a fault. The faulty component can also simply be exchanged.

6.1. Troubleshooting

Because of the interaction between the NC control unit, the supply and drive modules, the motor, the mechanical system and position measurement, poor performance of axis movements can be caused by a fault in the above devices or incorrect interfacing of individual components. The KDV 2.3 has a comprehensive diagnostic system for rapid fault location.

Safety guidelines

A fault increases the risk of an accident. Personnel, machinery and drives are at risk.



Troubleshooting and equipment repair must only be performed by trained personnel! This personnel must be able to recognize the dangers of electrical or mechanical equipment, and prevent dangerous situations!

Guidelines for protecting personnel



Personnel is not permitted in the danger zone.

Safety measures such as safety screens, covers, and light barriers must be present.

Access to the E-Stop button must be free and ready.



The following applies when working within the danger zone:

The power to the installation must be switched off and the system locked so that it cannot be switched back on when working within the danger zone.

Wait until the DC bus has completely discharged. Depending upon the DC bus capacitors used, discharge time can take several minutes. Verify voltage by measuring at X9 (L+/L-).

*Danger due to voltage
in conductive parts*

There can be dangerous voltages at the following connections:

- At all supply module connections and associated transformers, capacitors and additional bleeders. In particular, at the power connections (terminal X9), control voltage input X10, and the blower supply connections X13 and X14.
- At the drive modules, motors and the plug-in connectors of the motor.

Before working on electrical devices:



Use the mains disconnect to cut power to the entire installation. Make sure it cannot be switched back on!

Wait for the DC bus to discharge. Depending upon the DC bus capacitors, discharge can take several minutes. Verify voltage by measuring it at X9 (L+/L-).

Do not run motor. The motor connections are energized during any movements of the motor!

Before switching on:



Do not turn on power until the touch-cover shipped with each unit has been installed!

*Notes on protecting
the machine*

To avoid damage to the machine, note:



The initial start-up should only be performed by trained personnel. Make sure that the E-stop and the axis limit switches are operational.

*Notes on protecting
the unit*

Before switching on:



Make sure the circuitry agrees with the KDV terminal diagram and electrical schematics for the machine.

Electrostatic loads

Electrostatic loads are hazardous to electronic components. Therefore:





Ground all objects prior to contact with the units.

6.2. Diagnostics displays

Please note that the messages are only valid if the +24V- and +/-15V control voltages are fault free!

The fault messages "bleeder overload" and "ground short" can be cleared by pressing the reset key on the KDV 2.3 (key S2) or by switching off electronics power.

LEDs		OFF 	Steady light 
Bleeder overload	red	continuous bleeder operation within permissible range OK	shutdown due to high bleeder power, high mains voltage, or defective drive module
Ground connection	red	no ground short OK	shut down due to ground short in supply module, drive module, cables or in motor
Auxiliary voltage	green	no mains auxiliary voltage at terminals X10a/ L1 ... L3	mains auxiliary voltage OK
Power OK	green	no power or power outage	Power OK

KDV2_Diagnose.fh3

Figure 6.1: The diagnostics displays of the KDV 2.3

6.3. Fault list and remedial actions

Bleeder overload	LED "bleeder overload" is lit up red	(Fault message)
	<i>Cause 1: Start-stop frequency of the drives too high.</i>	
<i>Remedy</i>	Check load cycle.	
	<i>Cause 2: Drive energy too high.</i>	
<i>Remedy</i>	Check the drive energy.	
	<i>Cause 3: The bleeder is defective or there is a fault in the KDV2.3</i>	
<i>Remedy</i>	Replace the KDV 2.3.	

Ground connection	LED "ground short" lit up red	(Fault message)
	<i>Cause 1: Drive module is defective.</i>	
<i>Remedy</i>	Check drive module and replace, if necessary.	
	<i>Cause 2: Motor cable is damaged or there is a short in the housing.</i>	
<i>Remedy</i>	Check motor power cable and motor.	
	<i>Cause 3: Fault in the KDV2.3.</i>	
<i>Remedy</i>	Replace the KDV 2.3.	

Auxiliary voltage **LED "auxiliary voltage" not lit up** **(Fault message)**

Cause 1: Fuse F3 or F4 is defective

Remedy **Check fuses F3 and F4 and replace, if necessary.**

Cause 2: Voltage input interrupted.

Remedy **Check the voltage at X10a (230 V AC).**

Power O.K. **LED "power O.K." does not light up** **(Fault message)**

Cause 1: Voltage is too low, or a phase on X9 is missing

Remedy **Check mains input at X9 (3 x 220 V AC)**

Cause 2: DC bus voltage less than 200 V DC

Remedy **1. Remove the busbars to the drive and check the DC bus voltage at X9 (L+, L-). Note safety guidelines.**
2. Check the DC bus for short circuit.

(Fault message)

Bb1 contact does not close

Cause 1: There is a fault in one of the drives.

Remedy **Check drier diagnostics displays.**

Cause 2: There is a fault in the signal voltage of the wire-ribbon connection.

Remedy **1. Check whether the bus cable signal voltage (X1) is properly mounted.**
2. Check termination connection of the wire-ribbon connection (X1).

**+24 V and/or ±15V
No control voltage**

(Fault message)

Cause 1: There is no control voltage at X10a or it is faulty

Remedy **Check the mains fuses in the control cabinet**

Cause 2: Maximum signal voltage load exceeded

Remedy **1. Disconnect signal voltage bus cable (X1) to the drive modules and take new voltage readings.**
2. Disconnect signal voltage taps routed in the control cabinet outside the KDV2.3 or the drive module, and check for short-circuiting.

Cause 3: The fuses F2, F3 or F4 in the KDV 2.3 are defective

Check and replace fuses.

6.4. Fuses

Designation	Symbol	Fine-wire fuse 5 x 20mm
+24V (output)	F2	2A/250E medium-blow
auxiliary voltage fuse L1	F3	10A/250E slow-blow
auxiliary voltage fuse L3	F4	10A/250E slow-blow
heatsink blower	F6	0.63A/250E medium blow
Except for F6, all fuses are mounted to the front of the unit (F6 is on the blower).		

Figure 6.2: Fuses

7. Dimensional data

7.1. KDV 2.3 supply module - dimensional data

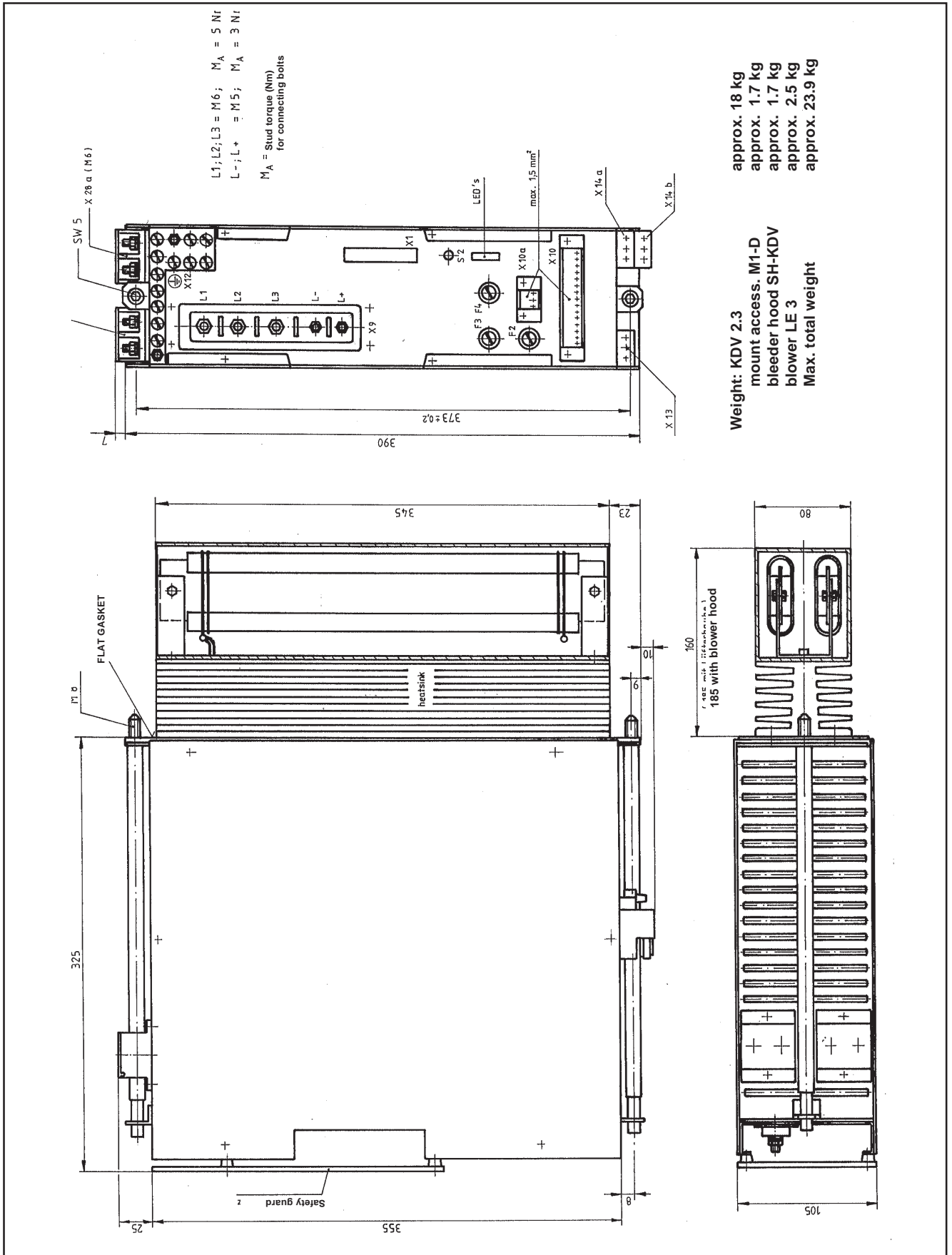

Figure 7.1: Dimensional data for the KDV 2.3 supply module

7.2. Dimensions: DST 3-phase AC autotransformer

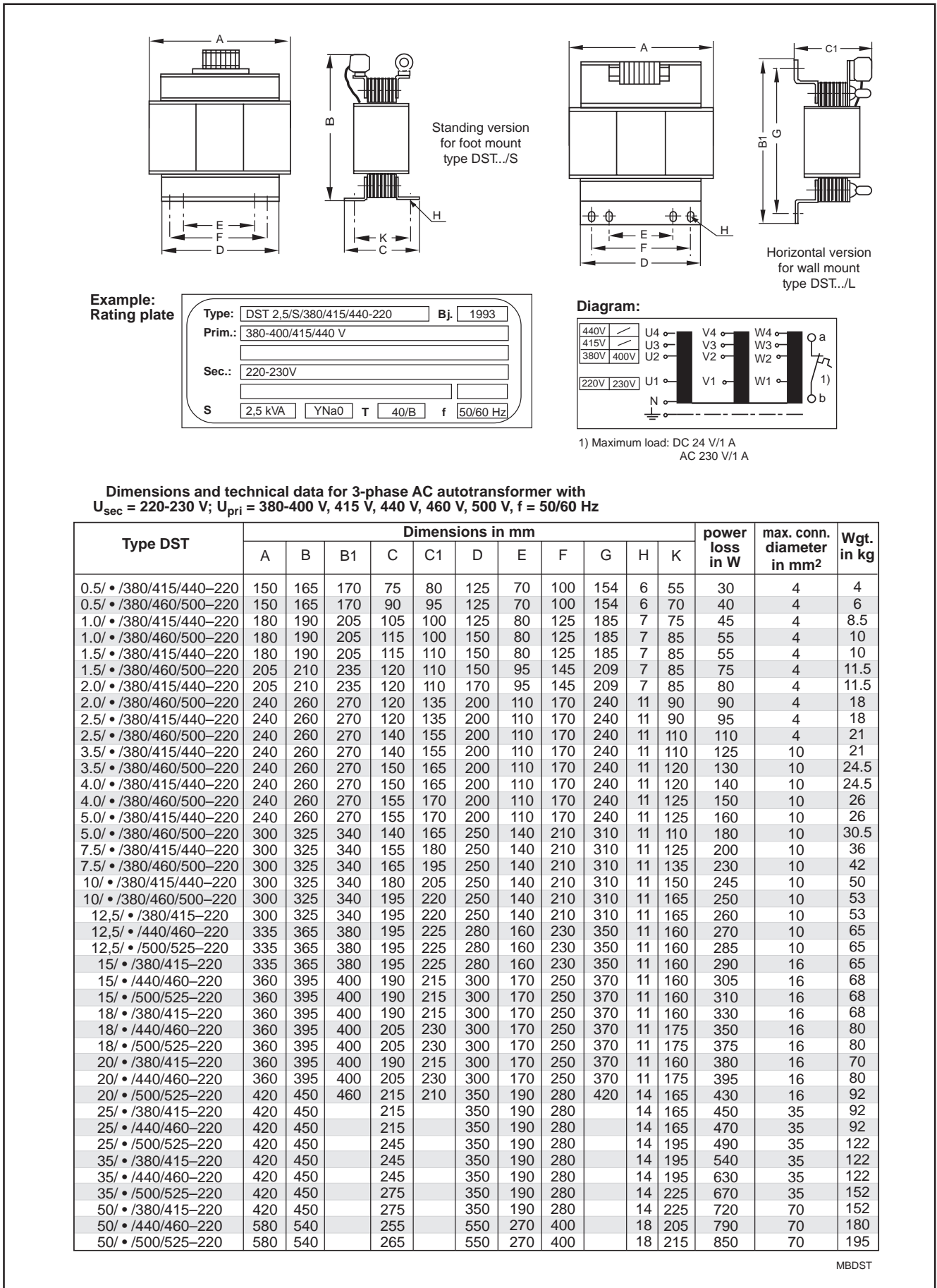
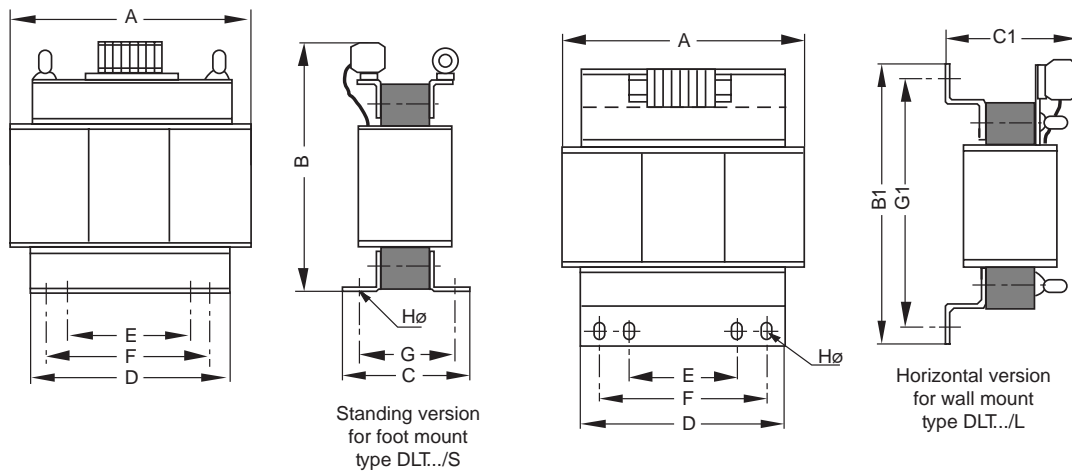

Figure 7.2: Dimensional data of the DST threephase AC autotransformer

7.3. Dimensions: DLT 3-phase AC isolation transformer



Example: rating plate

Type:	DLT 2,5/S/380/415/440-220	Bj.	1993
Prim.:	380-400/415/440 V		
Sec.:	220-230V		
S	2,5 kVA	Yyn0	T 40/B f 50/60 Hz

Diagram:

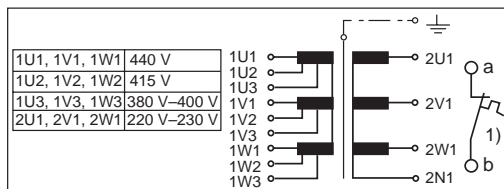

1) Maximum load: DC 24 V/1 A; AC 230 V/1 A

Dimensions and technical data for threephase isolation transformer with
 $U_{sec} = 220-230 V$; $U_{pri} = 380-400 V, 415 V, 440 V, 460 V, 500 V, f = 50/60 Hz$

Type DLT	Dimensions in mm											power loss in W	max. conn. diameter in mm ²	Wgt. in kg
	A	B	B1	C	C1	D	E	F	G	G1	H			
0.5/•/380/415/440-220	180	190	205	105	100	150	80	125	75	185	7	65	4	8.5
0.5/•/380/460/500-220	180	190	205	105	100	150	80	125	75	185	7	70	4	8.5
1.0/•/380/415/440-220	205	210	235	130	120	170	95	145	95	209	7	120	4	13
1.0/•/380/460/500-220	205	210	235	130	120	170	95	145	95	209	7	140	4	13
1.5/•/380/415/440-220	240	260	270	140	155	200	110	170	110	240	11	155	4	21
1.5/•/380/460/500-220	240	260	270	140	155	200	110	170	110	240	11	165	4	21
2.0/•/380/415/440-220	240	260	270	150	165	200	110	170	120	240	11	180	4	24.5
2.0/•/380/460/500-220	240	260	270	150	165	200	110	170	120	240	11	195	4	24.5
2.5/•/380/415/440-220	300	325	340	140	165	250	140	210	110	310	11	220	4	30.5
2.5/•/380/460/500-220	300	325	340	140	165	250	140	210	110	310	11	235	4	30.5
4.0/•/380/415/440-220	300	325	340	165	195	250	140	210	135	310	11	240	10	42
4.0/•/380/460/500-220	300	325	340	165	195	250	140	210	135	310	11	265	10	42
5.0/•/380/415/440-220	335	365	380	175	210	280	160	230	145	350	11	300	10	55
5.0/•/380/460/500-220	335	365	380	175	210	280	160	230	145	350	11	350	10	55
7.5/•/380/415/440-220	360	395	400	190	215	300	170	250	160	370	11	375	10	70
7.5/•/380/460/500-220	360	395	400	190	215	300	170	250	160	370	11	395	10	70
10/•/380/415/440-220	360	395	400	205	230	300	170	250	175	370	11	500	10	85
10/•/380/460/500-220	360	395	400	205	230	300	170	250	175	370	11	510	10	85
15/•/380-220	420	450		245		350	190	280	195		16	600	16	122
20/•/380-220	420	450		275		400	190	280	225		16	800	35	152
25/•/380-220	580	540		255		--	270	400	205		18	875	35	180
35/•/380-220	660	590		295		--	270	480	245		18	1000	70	275
50/•/380-220	660	655		305		--	270	480	255		18	1170	70	320

MBDLT

Figure 7.3: Dimensional data of the DLT threephase AC isolation transformer

7.4. Dimensional data: CZ 1.02 additional capacitor

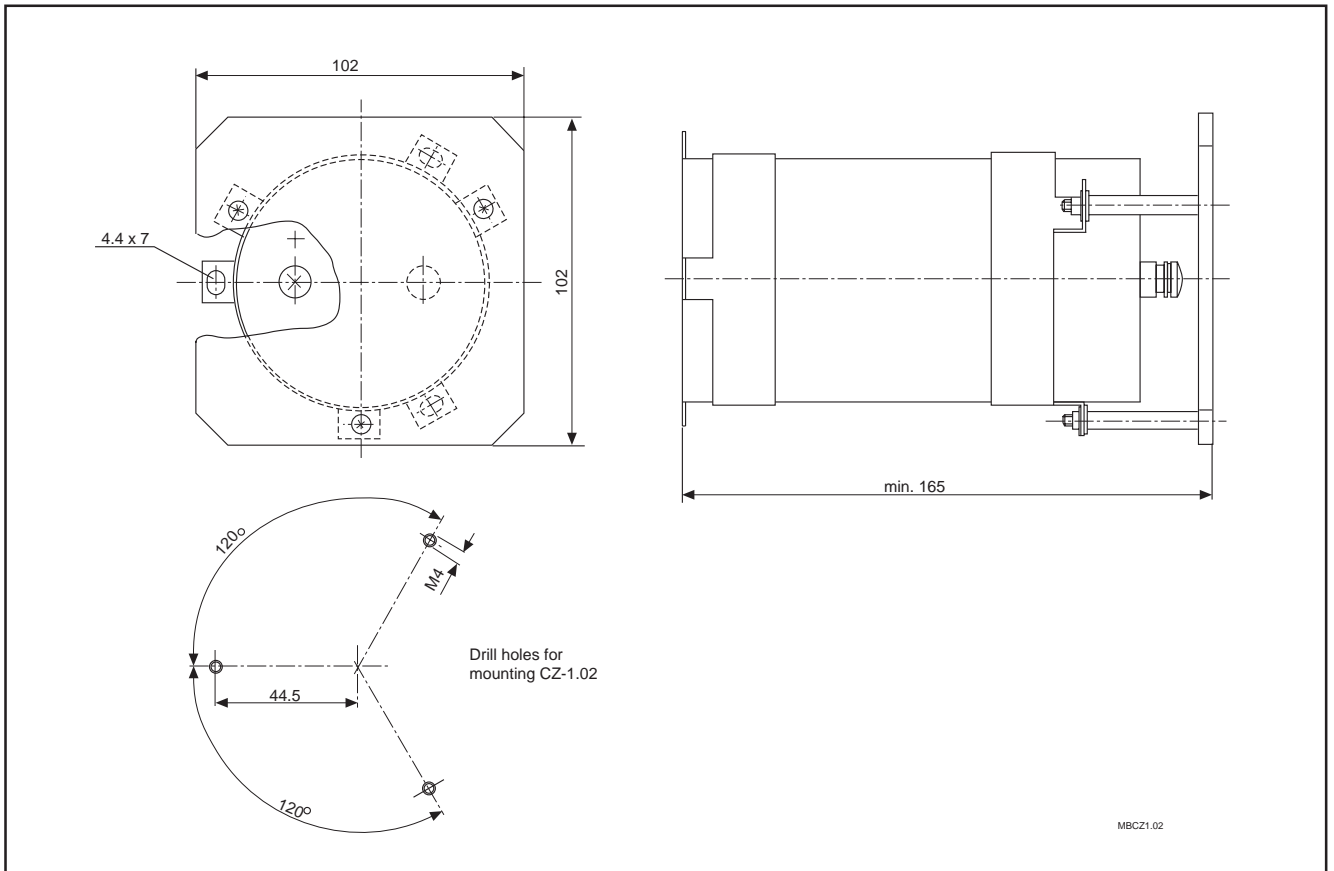

Figure 7.4: Dimensional data for the CZ 1.02 additional capacitor

7.5. Dimensional data: TCM 1.1 add. capacitor module

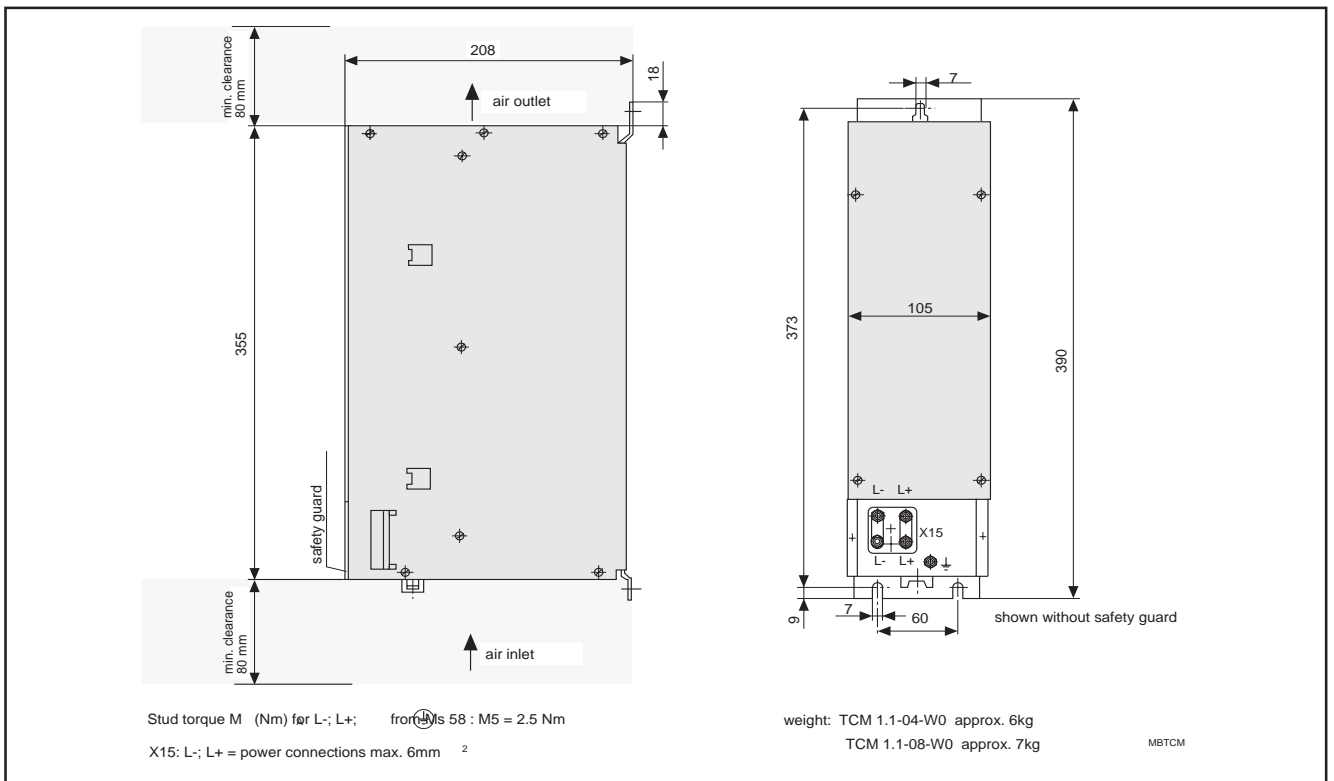

Figure 7.5: Dimensional data for the TCM additional capacitor module

7.6. Dimensional data: GLD 12/13 smoothing choke

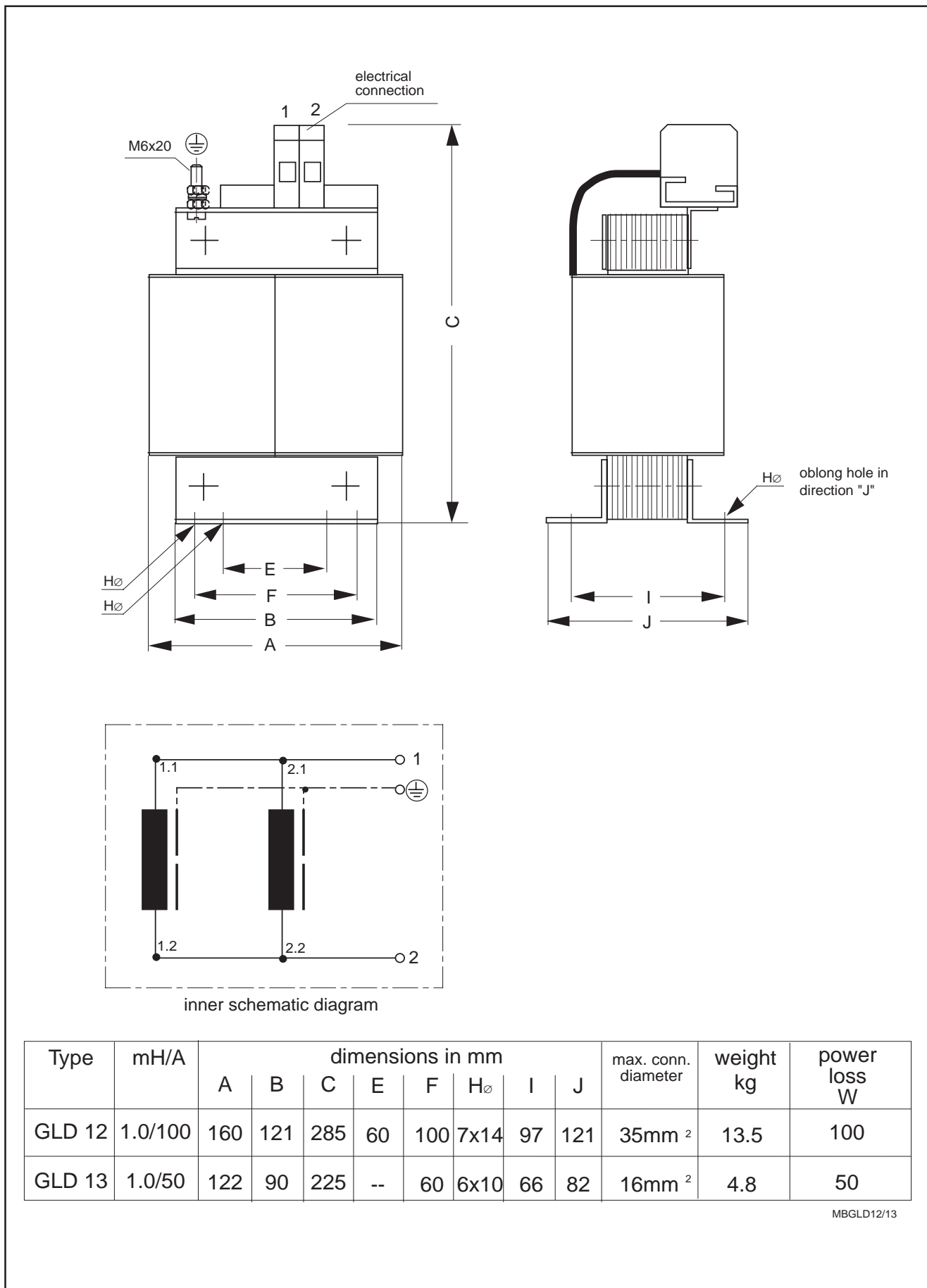

Figure 7.6: GLD 12/13 smoothing choke - dimensional data

7.7. Dynamic brake contactor

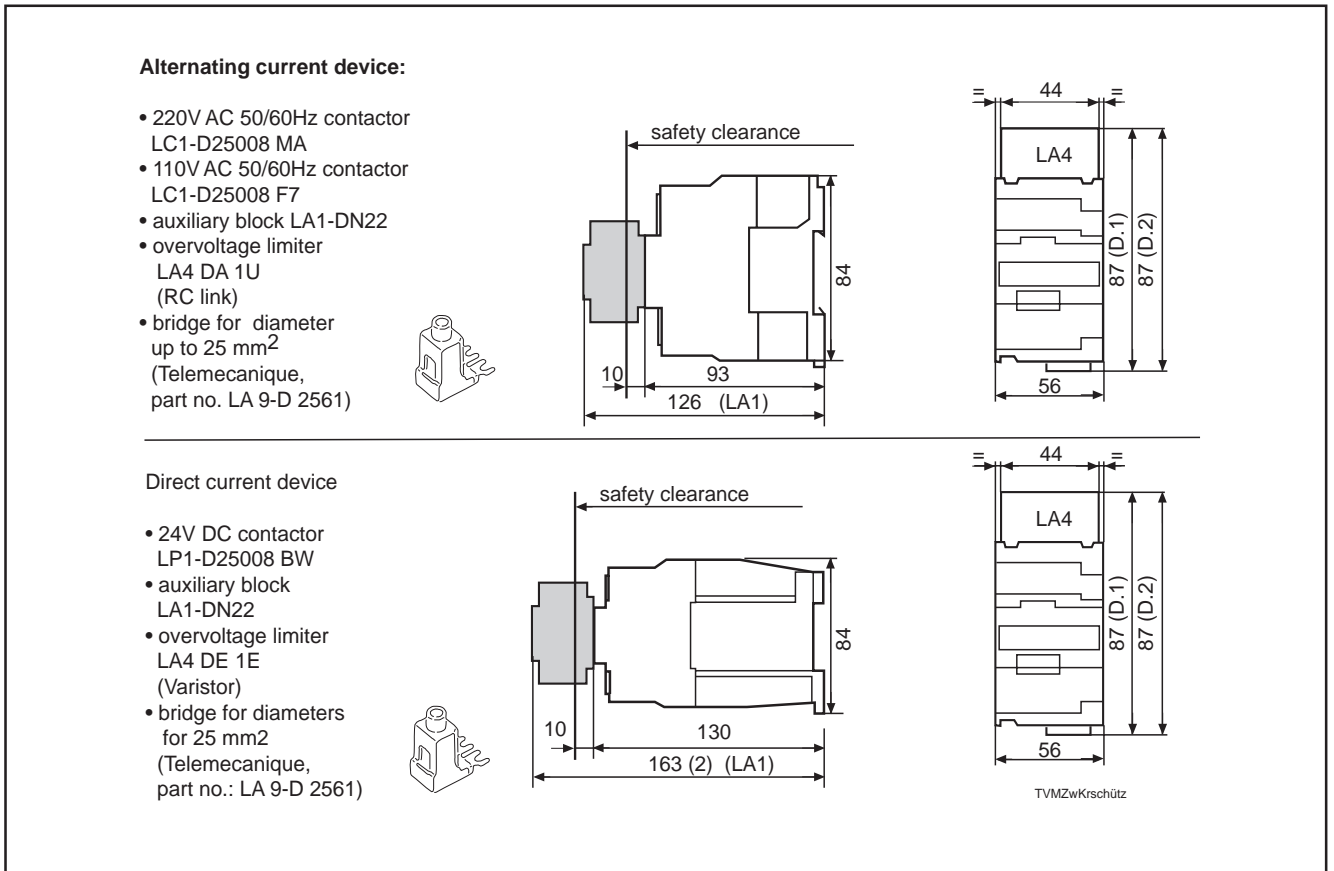

Figure 7.7: Dimensional data for dynamic brake contactor

7.8. Dynamic brake resistor

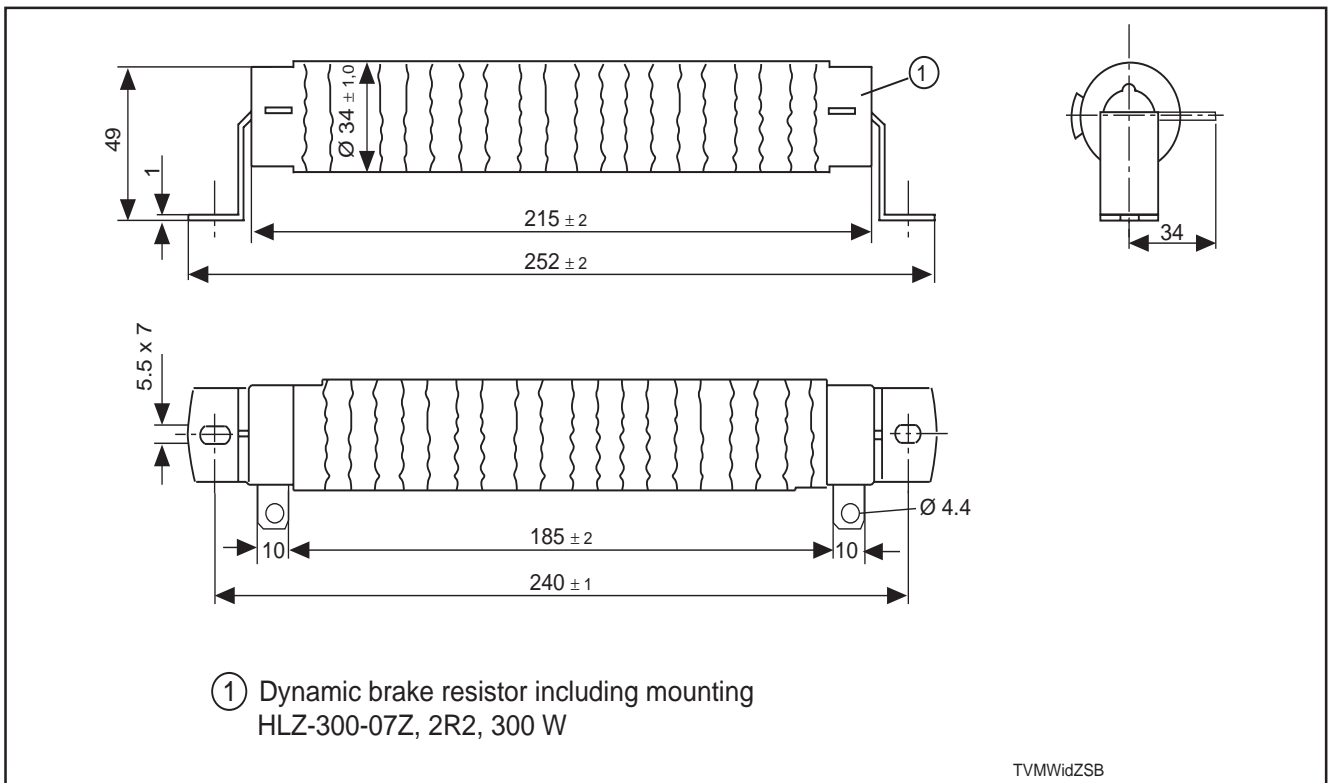

Figure 7.8: Dimensional data for dynamic brake resistor

8. Order details

8.1. KDV type codes

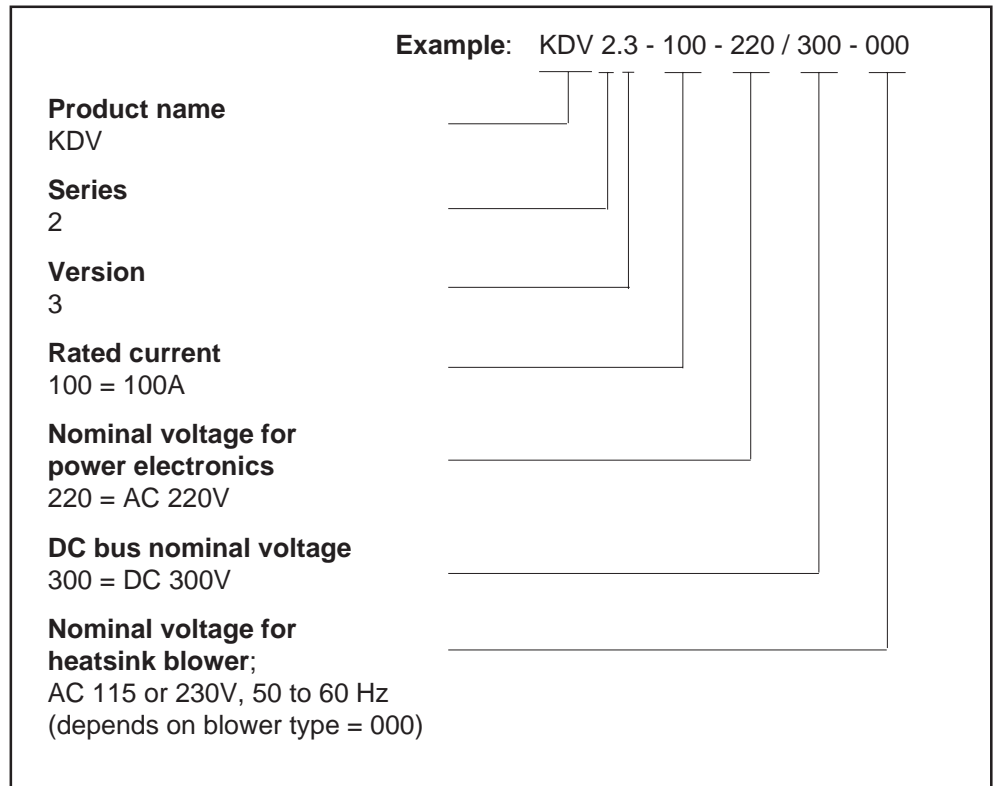

Figure 8.1: KDV type keys

8.2. Available versions

Designation	Available version
supply module	KDV 2.3 - 100 - 220 / 300 - 000
electrical connecting accessories (see section 8.3)	E10 - KDV E11 - KDV E12 - KDV
mechanical mounting accessories	M1 - KD
blower	LE 3 - 220 LE 3 - 115
smoothing choke	GLD 12 GLD 13
additional capacitors	CZ 1.02 TCM 1.1 - 04 - W0
matching transformer	DST (see section 7.2) DLT (see section 7.3)

Figure 8.2: Available versions

8.3. Summary of the electrical connecting accessories

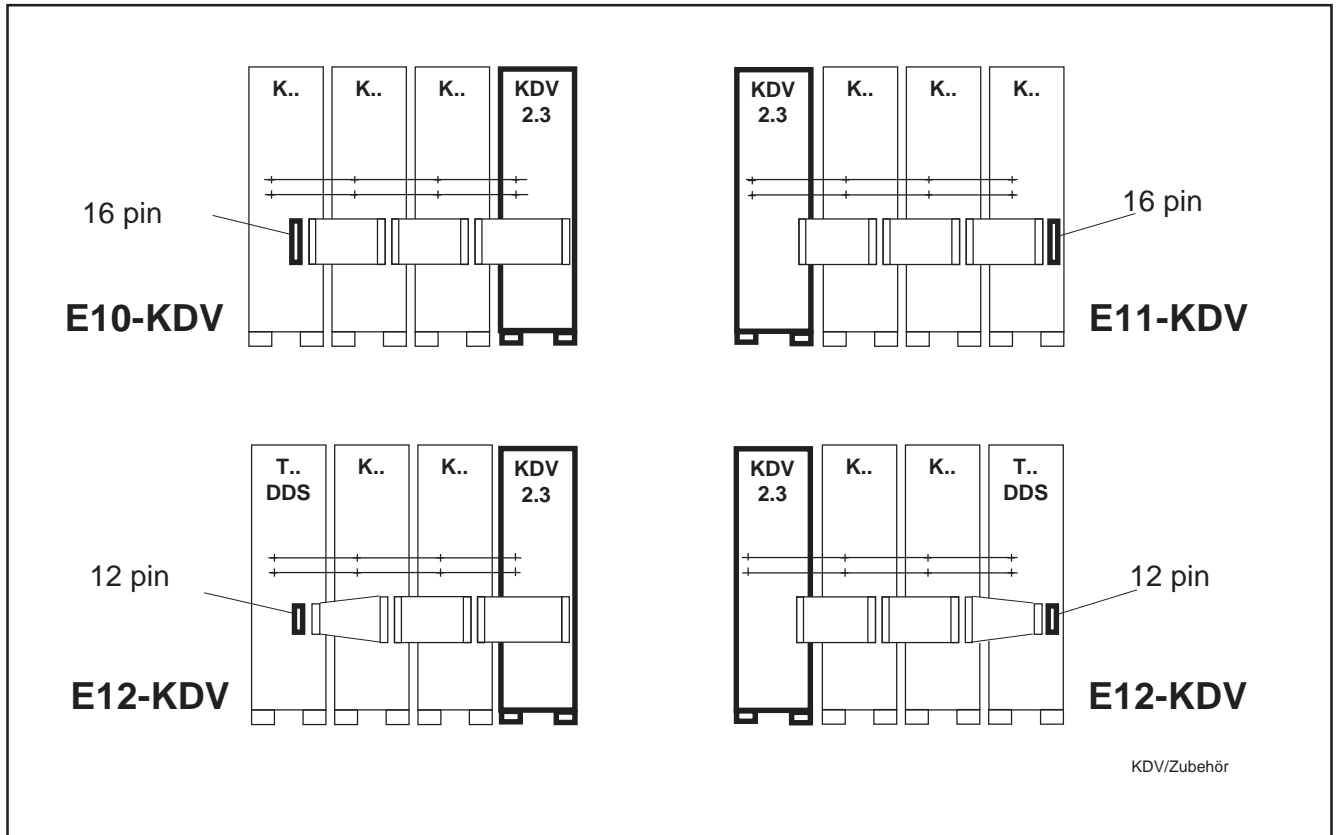

Figure 8.3: Summary of electrical connecting accessories

8.4. Order details for mains supply with KDV 2.3

Item	Article	See
1.0	supply module KDV 2.3 - 100 - 220 / 300 - 000	
1.1	mechanical mounting accessories M1-KD	
1.2	electrical connecting accessories E...-KDV	Sect. 8.3
1.3	blower unit LE 3 - ... bleeder cover SH-KD	Sect. 3.9, 3.14, 8.2
2.0	smoothing choke GLD ..	Sect. 2.2, 3.8, 7.6
3.0	additional capacitor CZ 1.02, TCM 1.1	Sect. 2.2, 3.7, 7.4, 7.5
4.0	threephase AC autotransformer DST. .../.../.../ - 220	Sect. 3.2, 7.2

Figure 8.4: Order details of mains supply with KDV 2.3

9. List of INDRAMAT service reps

GERMANY

Lohr:

Indramat GmbH
Bgm.-Dr.-Nebel-Str. 2
97816 Lohr am Main
Tel 0 93 52/40-0
Telex 6 89 421
Telefax 0 93 52/40-4885

Chemnitz:

Indramat GmbH
c/o Rexroth Vertriebs- und
Servicegesellschaft mbH
Beckerstraße 31
09120 Chemnitz
Tel 03 71/355-0
Telefax 03 71/355-230

Düsseldorf:

Indramat GmbH
Technisches Büro Ratingen
Harkortstraße 25
Postfach 32 02
40880 Ratingen 1
Tel 0 21 02/44 20 48 /-49
Telefax 0 21 02/41 315

Stuttgart:

Indramat GmbH
Technisches Büro
Liststraße 1/2
71229 Leonberg 1
Tel 0 71 52/25 076/-77
Telefax 0 71 52/25 034

AUSTRIA

G.L. Rexroth GmbH
Geschäftsbereich Indramat
Randlstraße 14
A - 4061 Pasching
Tel 07 229/44 01-72
Telefax 07 229/44 01-80

DENMARK

BEC Elektronik AS
Zinkvej 6
DK - 8900 Randers
Tel 086/44 78 66
Telefax 086/44 71 60

ENGLAND

G.L. Rexroth Ltd.
Indramat Division
4 Esland Place, Love Lane
Cirencester, Glos GL 7 1 YG
Tel 02 85/65 86 71
Telex 43 565
Telefax 02 85/65 49 91

FRANCE

Rexroth - Sigma
Division Indramat
Parc des Barbanniers
4, Place du Village
F - 92 632 Gennevilliers Cedex
Tel 1/47 98 44 66
Telex 616 581
Telefax 1/47 94 69 41

ITALY

Rexroth S.p.A.
Divisione Indramat
Via G. Di Vittorio, 1
I - 20 063 Cernusco S/N. MI
Tel 02/9 23 65 - 270
Telex 331 695
Telefax 02/92 10 80 69

NETHERLANDS

Hydraudyne Hydrauliek B.V.
Kruisbroeksestraat 1a
P.O.Box 32
NL - 5280 AA Boxtel
Tel 04 116/51 951
Telefax 04 116/51 483

SPAIN

Rexroth S.A.
Centro Industrial Santiga
Obradors s/n
E-08130 Santa Perpetua
de Mogoda (Barcelona)
Tel 03/7 18 68 51
Telex 59 181
Telefax 03/718 98 62

Goimendi S.A.
División Indramat
Jolastokieta (Herrera)
Apartado 11 37
San Sebastian, 20 017
Tel 043/40 01 63
Telex 36 172
Telefax 043/39 93 95

SWEDEN

AB Rexroth mecmam
Indramat Division
Varuvägen 7
S - 125 81 Stockholm
Tel 08/72 79 200
Telefax 08/99 75 15

REPUBLIC OF SLOVENIA

ISKRA Elektromotorji
Otoki 21
YU - 64 228 Zelezniki
Tel 064/66 441
Telex 34 578
Telefax 064/ 67 150

CANADA

Basic Technologies Corporation
Burlington Division
3426 Mainway Drive
Burlington, Ontario
Canada L7M 1A8
Tel 416/335 - 55 11
Telex 06 18 396
Telefax 416/335-41 84

MEXICO

Motorizacion y Diseño de
Controles
Av. Dr. Gustavo Baz No. 288
Col. Parque Industrial la loma
Apartado Postal No. 318
54 060 Tlalnepantla
Estado de Mexico
Tel 5/39 78 64 4
Telefax 5/39 89 88 8

USA

Rexroth Corporation
Indramat Division
255 Mittel Drive
Wood Dale, Illinois 60 191
Tel 708/8 60 - 10 10
Telex 206 582
Telefax 708/5 30 - 46 31

Rexroth Corporation
Indramat Division
2110 Austin Avenue
Rochester Hills, Michigan 48 309
Tel 313/853 - 82 90
Telefax 313/853 - 82 98

ARGENTINA

Mannesmann Rexroth S.A.I.C
Division Indramat
Acassusso 48 41/7
1605 Munro (Buenos Aires)
Argentina
Tel 01/7 56 01 40
01/7 56 02 40
Telex 26 266 rexro ar
Telefax 01/7 56 01 36

BRAZIL

Rexroth Hidráulica Ltda.
Divisão Indramat
Rua Heinrich Passold,130
CP 156
BR - 89. 107-000 Pomerode SC
Tel 04 73/87 03 21
Telex 47 32 88 REXR BR
Telefax 04 73/87 02 51

CHINA

G.L. Rexroth Ltd.
Shanghai Office
Room 206
Shanghai Intern. Trade Centre
2200 Yan Xi Lu
Shanghai 200335
P.R. China
Tel 2755-333
Telefax 2755-666

INDIA

G. L. Rexroth Industries Ltd.
Indramat Division
Plot. 96, Phase III
Peenya Industrial Area
Bangalore - 56 00 58
Tel 80/83 92 10 1
80/83 94 34 5

KOREA

Seo Chang Corporation Ltd.
Room 903, Jeail Building
44 - 35 Yeouido-Dong
Yeongdeungpo-Ku
Seoul, Korea
Tel 02/780 - 82 07 ~9
Telefax 02/784 - 54 08

AUSTRALIA

Australasian Machine Tool
Co. Pty. Ltd.
9 Webber Parade,
East Keilor (Melbourne)
Victoria, 30 33, Australia
Tel 03/336 78 22
Telefax 03/336 17 52

10. Index

A

Additional capacitance 17
Additional capacitance on the D.C. bus 17
Additional capacitor 9
Additional components required 9
Applications 7
Autotransformer 13
Auxiliary voltage 43

B

Bb1 contact 36
Bb1 contact does not open or close 43
Bleeder overload 42
Bleeder warning contact 37
Blower power supply 17
Busbars 16
BVW contact 37

C

Circuit breakers 14
Connecting accessories 51
Connection voltage 13
Continuous bleeder power 9
Continuous D.C. bus power 9
Continuous mechanical output 7
Continuous mechanical power 9
Continuous regenerative power 7
Control circuits 24
Control circuits for a controlled braking of the d 34
Control circuits with dynamic braking 30
Cooling with a central blower 23
Cooling with a heatsink blower 23
CZ 1.02 9

D

D.C. bus 16
D.C. bus dynamic brake 26
D.C. bus dynamic braking 25
D.C. bus peak power 9
D.C. bus short-time power 9
Diagnostics displays 42
Dimensional data 44
Drives - backing up 17

E

E-Stop disengaged 24
Electrical connecting accessories 51
Electronics supply 17
Electrostatic loads 41
Energy capacitor for power failures 17

F

- F2 43
- F3 43
- F4 43
- F6 43
- Fault current protective device 19
- Feedback power too high 37
- FI-current limiting type circuit breakers 19
- Functional power features of the KDV 2.3 8
- Fuse protection for the power connection 14
- Fuses 43

G

- Gear cutting machines 25
- GLD 12 9
- GLD 13 9
- Grounded threephase mains 15
- Guidelines for protecting personnel 40

H

- Heat loss 23
- Heatsink 23

I

- INDRAMAT AC drive system 5
- INDRAMAT service reps 52
- Installing the KDV 2.3 21

K

- KDV 2.3 - data 10
- KDV 2.3 power ratings 9
- KDV 2.3 supply module design 6
- KDV type codes 50

M

- Mains connection - power section 13
- Mains connection via transformer 13
- Mains contactor 14
- Maximum feedback energy 9
- Maximum permissible fusing 14
- Measuring and test purposes 36
- Mechanical mounting accessories 51

N

- NC bridge 38
- Non-periodic overvoltage 15
- Notes on protecting the unit 41

O

- Order details 50
- Output Bb1 36
- Output BVW 37
- Output NH 37
- Output UD 38

P

Peak bleeder power 9
Permissible overvoltage levels 15
Power O.K. 43
Power circuit breaker 14
Power connection 14
Power ratings 9
Power supply in order 38
Protection against accidental contact 16

S

Safety guidelines 40
Selecting the mains contactor 14
Signal voltages 36
Smoothing choke 9
Switching input power on and off 24

T

TCM 1.1 9
Terminal connector 18
Terminal diagram 12
Troubleshooting 40

U

UD contact 38
Ungrounded threephase mains 15

W

Wire-ribbon connection 18

X

X1 18

